

M - TAPERED AND REVOLVING HANDLES

UPDATE 05/2011



 **ROLLMEX**

M136 - M136CIN



BLACK-OXIDE STEEL AND STAINLESS STEEL REVOLVING AND FOLDING HANDLE AND FOLDING HANDLE

Material:

Reinforced polyamide.
Oils and freases resistant.

Surface:

Satin.

Colour:

Black (RAL 9011).

Inserts:

M136

- (1) Black-oxide treated steel revolving and folding stud with head for fitting screwdriver.
- (2) Black-oxide treated steel nut DIN 934.
- (3) Zinc plated steel spring.

M136 CIN

- (1) Stainless steel (AISI 303) revolving and folding stud with head for fitting screwdriver.
- (2) Stainless steel (AISI 304) nut DIN 934.
- (3) Stainless steel spring.

SPECIAL REQUESTS:

- It's possible to supply the inserts with a zinc plated treatment. (add CVZ to the end of article standard code).
- It's possible to supply colours as shown in the table at page 11 on this chapter.

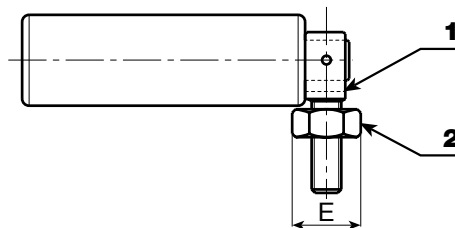
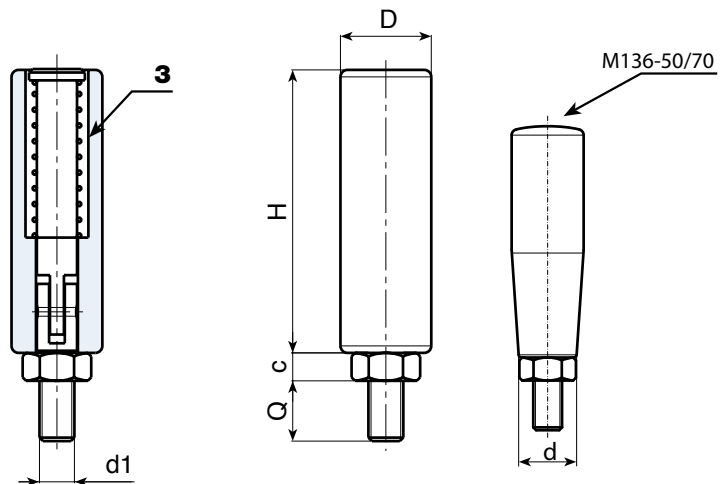

Version M136 - Black-oxide steel version

art.	H	D	d	E	d1 6g	c	Q	g	F1 (N)
M13650.TM06X0901	49	20	15	10 (11)	M06	5	9	39	270
M13670.TM08X1001	69	25	19	13 (15)	M08	6,5	10	71	840
M13682.TM10X1501	81	26	-	17 (19)	M10	8	15	152	1700
M13690.TM10X1501	89	26	-	17 (19)	M10	8	15	160	2700

Version M136 CIN - Stainless steel version

art.	H	D	d	E	d1 6g	c	Q	g	F1 (N)
M13650.TM06X0901CIN	49	20	15	10 (11)	M06	5	9	39	270
M13670.TM08X1001CIN	69	25	19	13 (15)	M08	6,5	10	71	840
M13682.TM10X1501CIN	81	26	-	17 (19)	M10	8	15	152	1700
M13690.TM10X1501CIN	89	26	-	17 (19)	M10	8	15	160	2700



M - TAPERED AND REVOLVING HANDLES

WWW.ROLLMEX.FI



M - 2

Presumable presence in the stock in %

(☹) 90% (😊) 40% (☺) 5% (☹)

© ROLLMEX® - Reproduction prohibited

REVOLVING HANDLE WITH STAINLESS STEEL HEXAGON SOCKET HEAD STUD

M129 CIN



INOX

Material:

Reinforced polyamide.
Oils and freases resistant.

Surface:

Satin.

Colour:

Black (RAL 9011).

Revolving Insert:

Zinc plated steel threaded stud with ring nut and hexagon socket head. Brass revolving ring.

SPECIAL REQUESTS:

- It's possible to supply colours as shown in the table at page 11 on this chapter.

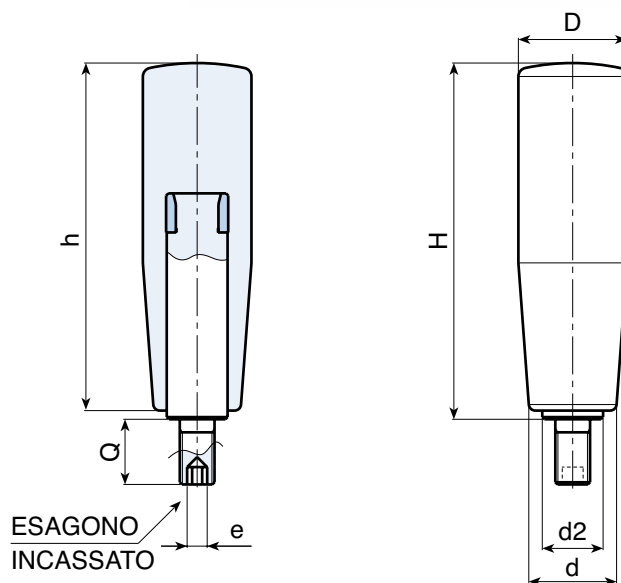

	art.	H	D	h	d	d1 6g	d2	e	Q	g
	M12950.TM06X1201CIN	52	20	51	16	M06	11	3	12	42
	M12960.TM06X1201CIN	62	23	60	18	M06	11	3	12	54
	M12960.TM08X1501CIN	62	23	60	18	M08	11	4	15	60
	M12970.TM08X1501CIN	72	25	70	19	M08	14	4	15	92
	M12970.TM10X1501CIN	72	25	70	19	M10	14	5	15	94
	M12980.TM08X1501CIN	81	25	79	20	M08	14	4	15	98
	M12980.TM10X1501CIN	81	25	79	20	M10	14	5	15	104
	M12980.TM12X1501CIN	82	26	81	20	M12	14	5	15	104
	M12990.TM10X1501CIN	93	27	90	22,5	M10	14	5	15	118
	M12990.TM12X1501CIN	93	27	90	22,5	M12	14	5	15	120

Presumable presence in the stock in %

90% 40% 5%

© ROLLMEX® - Reproduction prohibited

ROLLMEX

M - TAPERED AND REVOLVING HANDLES

M145 CIN



INOX

REVOLVING HANDLE WITH STAINLESS STEEL RING NUT

Material:

Reinforced polyamide.
Oils and freases resistant.

Surface:

Satin.

Colour:

Black (RAL 9011).

Revolving insert:

Zinc plated steel threaded stud with ring nut and wrench seat. Brass revolving ring.

SPECIAL REQUESTS:

- It's possible to supply colours as shown in the table at page 11 on this chapter.

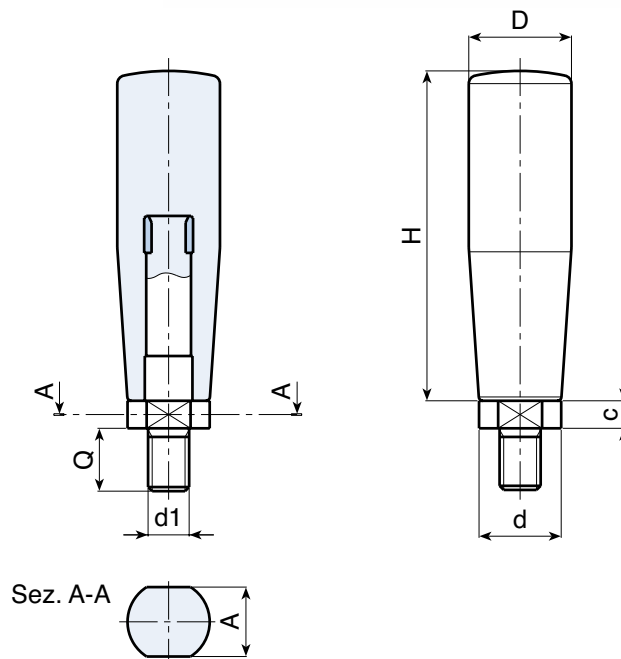

art.	H	D	d	d1 6g	c	A	Q	g
M14550.TM06X1201CIN	50	20	12	M06	5	10	12	32
M14560.TM08X1501CIN	60	23	18	M08	6	16	15	74
M14570.TM08X1501CIN	69	25	18	M08	7	16	15	82
M14570.TM10X1501CIN	69	25	18	M10	7	16	15	86
M14580.TM10X1501CIN	80	25	20	M10	7	17	15	92
M14580.TM12X1501CIN	80	25	20	M12	7	17	15	96
M14590.TM10X1501CIN	89	27	20	M10	7	17	15	104
M14590.TM12X1501CIN	89	27	20	M12	7	17	15	108

REVOLVING AND FOLDING HANDLE WITH ROUND STAINLESS STEEL BASE

M204 CIN



PA6
+GF

UL94
HB



INOX

Material:

Reinforced polyamide.
Oils and freases resistant.

Surface:

Satin.

Colour:

Black (RAL 9011).

Inserts:

- (1) Stainless steel (AISI 303) revolving and folding mechanism.
- (2) Stainless steel (AISI 304) reference pin DIN934.
- (3) Stainless steel spring.

SPECIAL REQUESTS:

- It's possible to supply colours as shown in the table at page 11 on this chapter.
- Su richiesta e per quantità l'inserto può essere fornito in acciaio brunito, zincato o AISI 304.

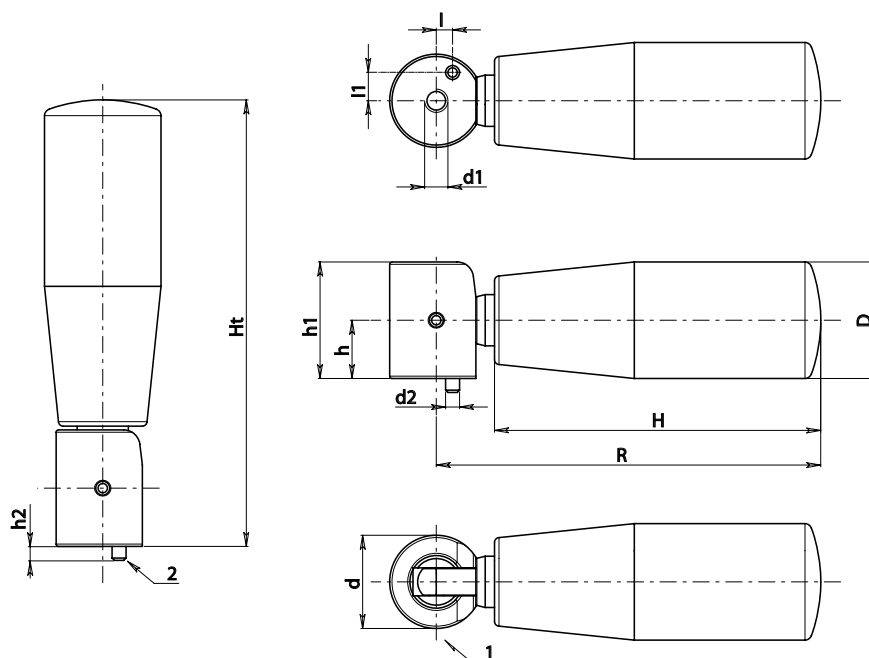

art.	H	D	d	R	Ht	h	h1	h2	d1	d2	l	l1	g
M20470.TM0501CIN	70	25	20	82,5	96	12,5	25	3	M05	3	3,5	6,1	48

Presumable presence in the stock in %

(☺) 90% (☹) 40% (☹) 5%

© ROLLMEX® - Reproduction prohibited

ROLLMEX

M - TAPERED AND REVOLVING HANDLES

M229 - M229CIN



"EUROMODEL" REVOLVING HANDLE WITH HEXAGON SOCKET HEAD STUD

Material:

Reinforced polyamide.
Oils and freases resistant.

Surface:

Satin.

Colour:

Black (RAL 9011).

Central Cap:

Grey ABS (RAL 7035 cod. 13).

Alternative Cap Colour:

Orange (RAL 2004 cod. 02)

Blue (RAL 5015 cod. 07)

Yellow (RAL 1021 cod. 10)

Red (RAL 3000 cod. 16)

Green (RAL 6024 cod. 17)

Black (RAL 9011 cod. 01)

Revolving Insert:

M229:

Zinc plated steel threaded stud with ring nut and hexagon socket head. Brass revolving ring.

M229 CIN:

Stainless steel (AISI 303) threaded stud with ring nut and hexagon socket head. Brass revolving ring.



SPECIAL REQUESTS:

- It's possible to supply colours as shown in the table at page 11 on this chapter.

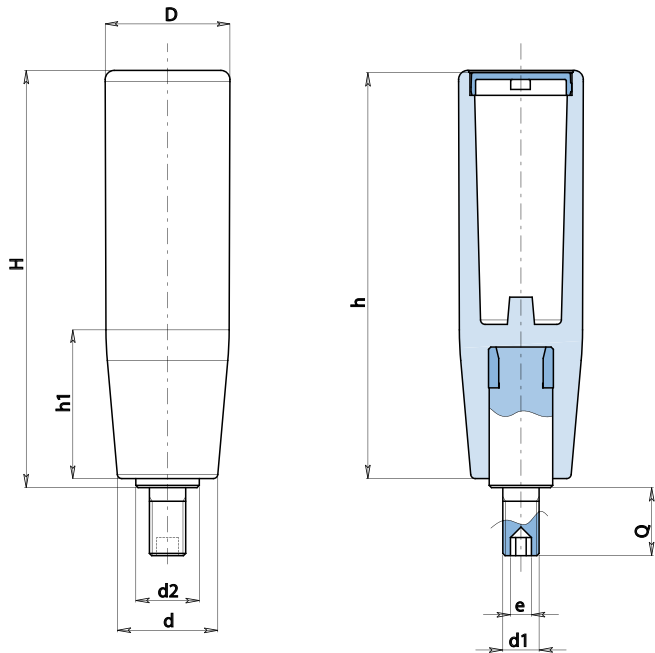

Version M229 - Zinc plated steel version

art.	H	D	d	d2	e	h	h1	d1 6g	Q	g
M22990.TM10X150113	91,5	27	22	14	5	89,5	32	M10	15	78
M22990.TM12X150113	91,5	27	22	14	5	89,5	32	M12	15	82

Version M229 CIN - Stainless steel version

art.	H	D	d	d2	e	h	h1	d1 6g	Q	g
M22990.TM10X150113CIN	91,5	27	22	14	5	89,5	32	M10	15	78
M22990.TM12X150113CIN	91,5	27	22	14	5	89,5	32	M12	15	82



"EUROMODEL" REVOLVING HANDLE WITH RING NUT

M245 - M245CIN



INOX

Material:

Reinforced polyamide.
Oils and freases resistant.

Surface:

Satin.

Colour:

Black (RAL 9011).

Central Cap:

Grey ABS (RAL 7035 cod. 13).

Alternative Cap Colour:

Orange (RAL 2004 cod. 02)
Blue (RAL 5015 cod. 07)
Yellow (RAL 1021 cod. 10)
Red (RAL 3000 cod. 16)
Green (RAL 6024 cod. 17)
Black (RAL 9011 cod. 01)

Revolving Insert:

M245:

Zinc plated steel threaded stud with ring nut and wrench seat. Brass revolving ring.

M229 CIN:

Stainless steel (AISI 303) threaded stud with ring nut and wrench seat. Brass revolving ring.

SPECIAL REQUESTS:

- It's possible to supply colours as shown in the table at page 11 on this chapter.

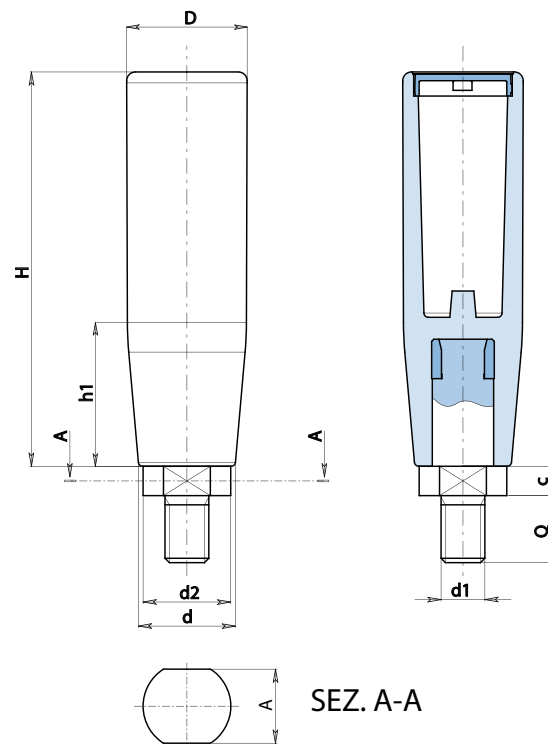

Version M245 - Zinc plated steel version

art.	H	D	d	A	c	h1	d1	6g	Q	g
M24590.TM10X150113	89,5	27	22	17	7	32	M10	15	89	89
M24590.TM12X150113	89,5	27	22	17	7	32	M12	15	89	89

Version M245 CIN - Stainless steel version

art.	H	D	d	A	c	h1	d1	6g	Q	g
M24590.TM10X150113CIN	89,5	27	22	17	7	32	M10	15	89	89
M24590.TM12X150113CIN	89,5	27	22	17	7	32	M12	15	89	89

Presumable presence in the stock in %

(☹) 90% (☺) 40% (☹) 5% (☹)

© ROLLMEX® - Reproduction prohibited

ROLLMEX

M - TAPERED AND REVOLVING HANDLES

M238



PA6
+GF

UL94
HB



"EUROMODEL" HANDLE WITH TAPERED HOLE

Material:

Reinforced polyamide.
Oils and freases resistant.

Surface:

Satin.

Colour:

Black (RAL 9011).

Central Cap:

Grey ABS (RAL 7035 cod. 13).

Alternative Cap Colour:

Orange (RAL 2004 cod. 02)

Blue (RAL 5015 cod. 07)

Yellow (RAL 1021 cod. 10)

Red (RAL 3000 cod. 16)

Green (RAL 6024 cod. 17)

Black (RAL 9011 cod. 01)

Hole:

Female threaded blind hole obtained by moulding the plastic. (Thread cannot be checked by Go-No Go gauge 6g-6H)

SPECIAL REQUESTS:

- It's possible to supply colours as shown in the table at page 11 on this chapter.

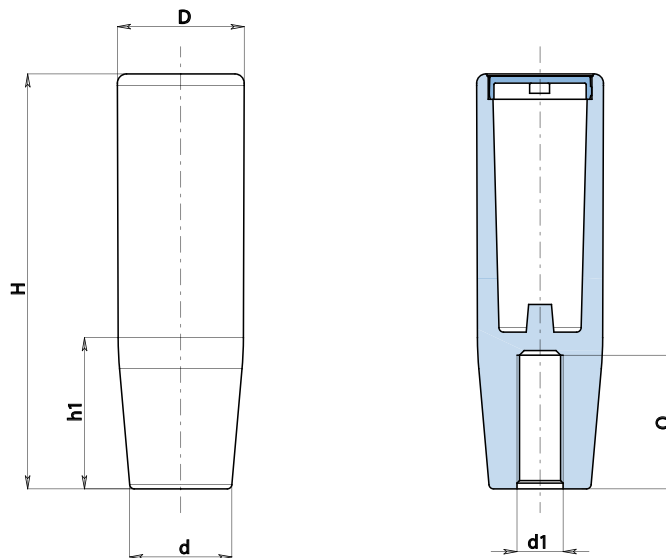

art.	H	D	d	h1	d1	Q	g
☹️ M23890.TM080113	89,5	27	22	32	M08	30	40
😊 M23890.TM100113	89,5	27	22	32	M10	30	39
☹️ M23890.TM120113	89,5	27	22	32	M12	30	37

"EUROMODEL" HANDLE WITH THREADED STUD

M240



Material:

Reinforced polyamide.
Oils and freases resistant.

Surface:

Satin.

Colour:

Black (RAL 9011).

Central Cap:

Grey ABS (RAL 7035 cod. 13).

Alternative Cap Colour:

Orange (RAL 2004 cod. 02)
Blue (RAL 5015 cod. 07)
Yellow (RAL 1021 cod. 10)
Red (RAL 3000 cod. 16)
Green (RAL 6024 cod. 17)
Black (RAL 9011 cod. 01)



Main Insert:

Zinc plated steel theaded stud. (tolerance 6g).

SPECIAL REQUESTS:

- It's possible to supply colours as shown in the table at page 11 on this chapter.

Stud lengths already available on tool:

M08 = 10-15-20-25-30-35-40-45-50-55-60-65-70-75-80

M10 = 10-15-20-25-30-35-40-45-50-55-60-65-70-75-80

M12 = 10-15-20-25-30-35-40-45-50-55-60-65-70-75-80

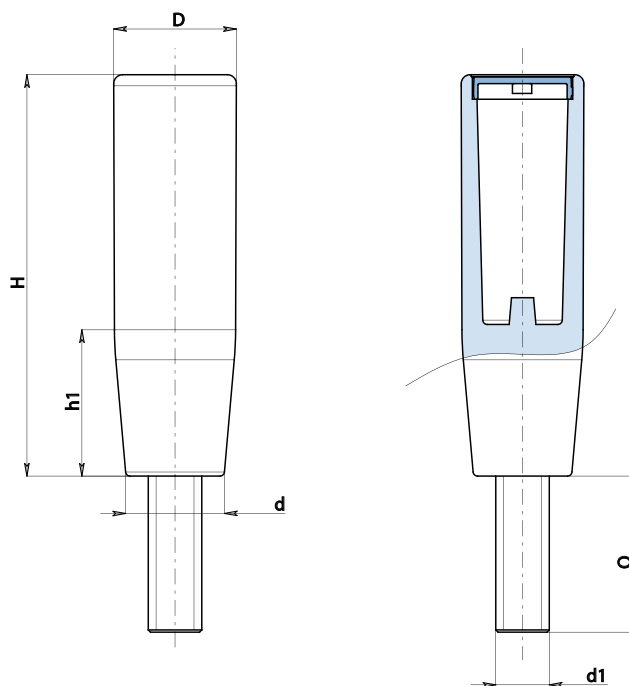

art.	H	D	d	h1	d1 - 6g	Q	LM	g
M24090.TM08X..0113	89,5	27	22	32	M08	10-20-30	80	65-68-71
M24090.TM10X..0113	89,5	27	22	32	M10	10-20-30	80	70-75-80
M24090.TM12X..0113	89,5	27	22	32	M12	20-30-40	80	83-90-97

LM = Maximum mouldable lenght

Enter the stud lenght in the two .. of the code number

Presumable presence in the stock in %

(☺) 90% (☹) 40% (⊖) 5% (⊕)

© ROLLMEX® - Reproduction prohibited

ROLLMEX

M - TAPERED AND RE- VOLVING HANDLES

M246



PA6
+GF

UL94
HB



"EUROMODEL" HANDLE WITH SELF-FIX HOLE

Material:

Reinforced polyamide.
Oils and freases resistant.

Surface:

Satin.

Colour:

Black (RAL 9011).

Central Cap:

Grey ABS (RAL 7035 cod. 13).

Alternative Cap Colour:

Orange (RAL 2004 cod. 02)

Blue (RAL 5015 cod. 07)

Yellow (RAL 1021 cod. 10)

Red (RAL 3000 cod. 16)

Green (RAL 6024 cod. 17)

Black (RAL 9011 cod. 01)

Hole:

Female smooth blind hole obtained by moulding the plastic.

Fixing:

Push fit.

SPECIAL REQUESTS:



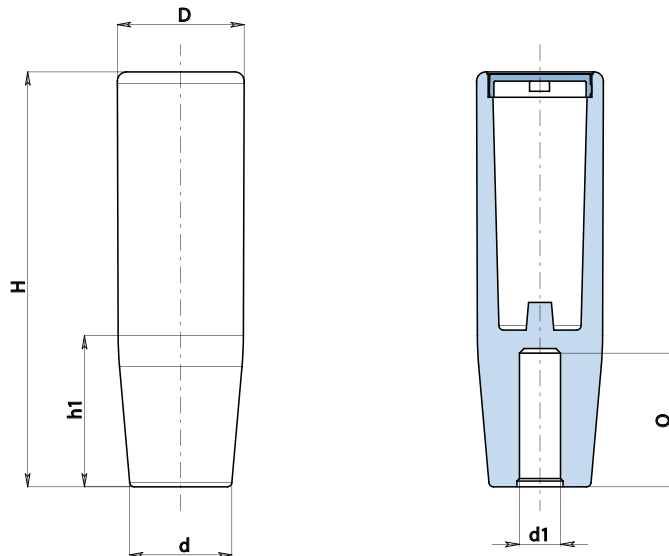









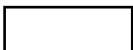

- It's possible to supply colours as shown in the table at page 11 on this chapter.







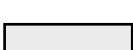







	art.	H	D	d	h1	d1	Q	g
	M24690.TG080113	89,5	27	22	32	D08	28	40
	M24690.TG100113	89,5	27	22	32	D10	28	39
	M24690.TG120113	89,5	27	22	32	D12	28	38
	M24690.TG140113	89,5	27	22	32	D14	28	37

COLOUR CHART

RAL COLOURS CODING

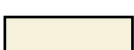
Colour		RAL	Cod.
Black		9011	01
Orange		2004	02
Orange		2011	03
White		9010	04
Blue		5002	05
Blue		5005	06
Blue		5015	07
Blue		5018	19
Blue		5019	21
Blue		5010	22
Yellow		1007	09
Yellow		1023	10
Grey		7024	12
Grey		7035	13
Red		3000	16
Green		6024	17

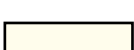
OTHER COLORS

Colour		Ref.	Cod.
White		-	52
Blue		-	53
Blue		pant. 645 U	54
Blue		pant. 300	55
Grey		-	57
Grey		-	59
Grey		NCS 7500	60
Red		-	64
Red		-	65
Natural		-	66
Green		-	70
Brown		-	71
Cream		-	72
Violet		-	73



WWW.ROLLMEX.FI

ROLLMEX Oy

Takojankatu 4 - 33540 TAMPERE
Push. 010-6661122 - Fax 03-3640072
 tampere@rollmex.fi

Karjalankatu 21 - 15140 LAHTI
Push. 010-6661121 - Fax 03-7511026
 lahti@rollmex.fi

AUTHORISED RESELLER



ver. MUK.10-0511