

G - FAMILY LOCKING HANDWHEELS



 **ROLLMEX**

ART. G730

4-LOBE HANDWHEEL WITH THREADED INSERT

MATERIAL:

Reinforced polyamide.
Oils and greases resistant.

SURFACE:

Satin.

COLOUR:

Black (RAL 9011).

MAIN INSERT:

Brass blind threaded bush.

(*) Zinc plated steel blind threaded bush.

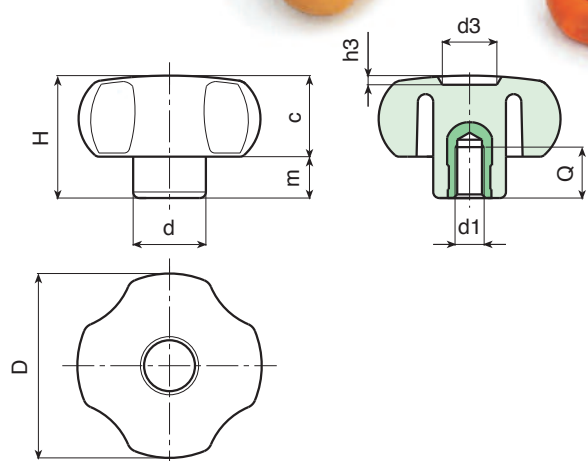

SPECIAL REQUESTS:

- It is possible to supply the inserts in different materials, on request and for quantities.
- It is possible to supply colours as shown in the table at page 19, on request and for quantities.

Art.	D	H	d	c	m	d3	h3	d1	Q	Weight (gr)
G730-20 M04	21	14	11	8,5	5,5	8	1,5	M04	13	5
G730-20 M05	21	14	11	8,5	5,5	8	1,5	M05	13	5
G730-20 M06	21	14	11	8,5	5,5	8	1,5	M06	13	5
G730-25 M04	26	16	12	10	6	10	1,5	M04	7	6
G730-25 M05	26	16	12	10	6	10	1,5	M05	7	6
G730-25 M06	26	16	12	10	6	10	1,5	M06	7	7
G730-25 M08	26	16	12	10	6	10	1,5	M08	7	8
G730-30 M05	30	23	15	13,5	9,5	12	2	M05	13	12
G730-30 M06	30	23	15	13,5	9,5	12	2	M06	10	12
G730-30 M08	30	23	15	13,5	9,5	12	2	M08	16	14
G730-30 M10	30	23	15	13,5	9,5	12	2	M10	16	14
G730-40 M05	40,5	29,5	15,5	18,5	11	12	3	M05	13	21
G730-40 M06	40,5	29,5	15,5	18,5	11	12	3	M06	10	21
G730-40 M08	40,5	27,5	15	18,5	11	12	3	M08	14	22
G730-40 M10	40,5	29,5	17,5	18,5	11	12	3	M10	13	26
G730-40 M12	40,5	29,5	21	18,5	11	12	3	M12	11	30
G730-50 M06	52	32,5	20,5	21,5	11	14,5	2,5	M06	10	35
G730-50 M08	52	32,5	20,5	21,5	11	14,5	2,5	M08	14	42
G730-50 M10	52	32,5	20,5	21,5	11	14,5	2,5	M10	13	43
G730-50 M12	52	32,5	20,5	21,5	11	14,5	2,5	M12	17	48
G730-60 M08	59	40	23	25	15	24	4	M08	15	60
G730-60 M10	59	40	23	25	15	24	4	M10	14	62
G730-60 M12	59	40	23	25	15	24	4	M12	18	67
G730-60 M14	59	40	23	25	15	24	4	M14	19	70
G730-60 M16	59	40	23	25	15	24	4	(*) M16	17	82
G730-80 M10	79	41	30	24	17	21	3	M10	14	88
G730-80 M12	79	41	30	24	17	21	3	M12	16	88
G730-80 M14	79	41	30	24	17	21	3	M14	19	97
G730-80 M16	79	41	30	24	17	21	3	(*) M16	17	109
G730-80 M20	79	41	30	24	17	21	3	(*) M20	16	115

**G-LOCKING
HANDWHEELS**

ROLLMEX

4-LOBE HANDWHEEL WITH THREADED THROUGH INSERT

MATERIAL:

Reinforced polyamide.
Oils and greases resistant.

SURFACE:

Satin.

COLOUR:

Black (RAL 9011).

MAIN INSERT:

Brass right through threaded bush.
(*) Zinc plated steel right through threaded bush.



SPECIAL REQUESTS:

- It is possible to supply the inserts in different materials, on request and for quantities.
- It is possible to supply colours as shown in the table at page 19, on request and for quantities.

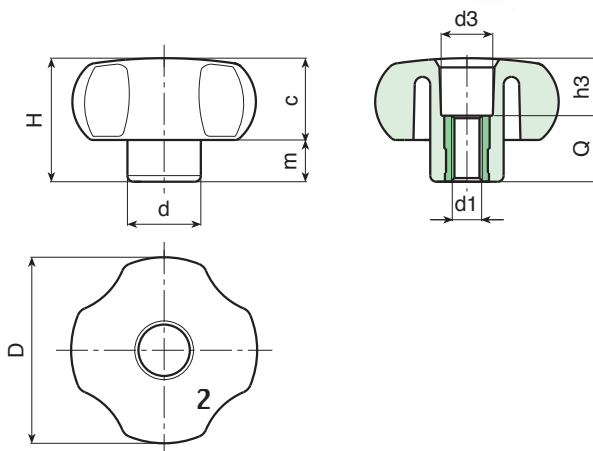

Art.	D	H	d	c	m	d3	h3	d1	Q	Weight (gr)
G731-20 M04	21	14	11	8,5	5,5	8	4,5	M04	9,5	4
G731-20 M05	21	14	11	8,5	5,5	8	7,5	M05	6,5	5
G731-20 M06	21	14	11	8,5	5,5	8	7,5	M06	6,5	5
G731-25 M04	26	16	12	10	6	9	7,5	M04	8,5	5
G731-25 M05	26	16	12	10	6	9	9,5	M05	6,5	6
G731-25 M06	26	16	12	10	6	9	9,5	M06	6,5	6
G731-25 M08	26	16	12	10	6	10,5	1,5	M08	14,5	10
G731-30 M05	30	23	15	13,5	9,5	12	8,5	M05	14,5	11
G731-30 M06	30	23	15	13,5	9,5	12	8,5	M06	14,5	11
G731-30 M08	30	23	15	13,5	9,5	12	8,5	M08	14,5	12
G731-30 M10	30	23	15	13,5	9,5	12	8,5	M10	14,5	13
G731-40 M06	41	29,5	16	18,5	11	13	11,5	M06	18	21
G731-40 M08	41	29,5	16	18,5	11	13	11,5	M08	18	21
G731-40 M10	41	29,5	16	18,5	11	13	11,5	M10	18	23
G731-40 M12	41	29,5	21	18,5	11	13	11,5	M12	18	26
G731-50 M06	52	32,5	20,5	21,5	11	13,5	14,5	M06	18	37
G731-50 M08	52	32,5	20,5	21,5	11	13,5	14,5	M08	18	38
G731-50 M10	52	32,5	20,5	21,5	11	13,5	14,5	M10	18	39
G731-50 M12	52	32,5	20,5	21,5	11	13,5	14,5	M12	18	40
G731-60 M08	59	40	23	25	15	20	22	M08	18	54
G731-60 M10	59	40	23	25	15	20	22	M10	18	55
G731-60 M12	59	40	23	25	15	20	22	M12	18	55
G731-60 M14	59	40	23	25	15	20	22	M14	18	56
G731-80 M08	79	41	30,5	24	17	20	23	M08	18	80
G731-80 M10	79	41	30,5	24	17	20	23	M10	18	82
G731-80 M12	79	41	30,5	24	17	20	23	M12	18	79
G731-80 M14	79	41	31	24	17	20	23	M14	18	80
G731-80 M16	79	41	30,5	24	17	21	15	(*) M16	26	102

4-LOBE HANDWHEEL WITH THREADED STUD

MATERIAL:

Reinforced polyamide.
Oils and greases resistant.

SURFACE:

Satin.

COLOUR:

Black (RAL 9011).

MAIN INSERT:

Zinc plated steel threaded stud.

SPECIAL REQUESTS:

- It is possible to supply the inserts with different lengths, on request and for quantities.
- It is possible to supply the inserts in different materials, on request and for quantities.
- It is possible to supply colours as shown in the table at page 19, on request and for quantities.

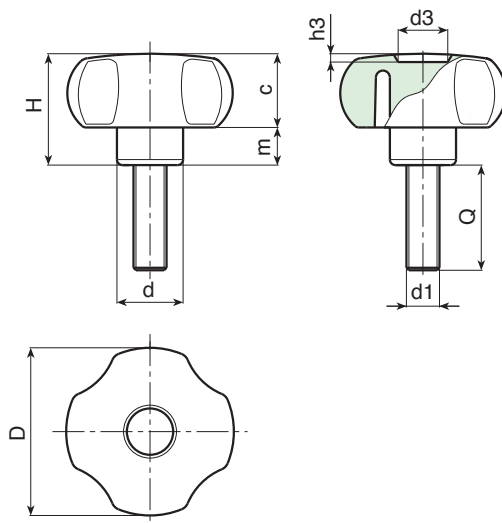

Art.	D	H	d	c	m	d3	h3	d1	Q	Weight (gr)
G732-20 M04	21	14	11	8,5	5,5	8	1,5	M04	10-16-20-30	4-4,5-5-6
G732-20 M05	21	14	11	8,5	5,5	8	1,5	M05	10-16-20-30	6-6,5-7-8
G732-20 M06	21	14	11	8,5	5,5	8	1,5	M06	10-16-20-30-40	6,5-7,5-8-9,5-11
G732-25 M04	26	16	12	10	6	10	1,5	M04	10-16-20-30	6-6-7-8
G732-25 M05	26	16	12	10	6	10	1,5	M05	10-16-20-30-40	8-8,5-9-10-11
G732-25 M06	26	16	12	10	6	10	1,5	M06	10-16-20-30-40	10-11-13-15-16
G732-25 M08	26	16	12	10	6	10	1,5	M08	16-20-30-40	14-16-20-24
G732-30 M05	30	23	15	13,5	9,5	12	2	M05	10-16-20-30-40	12-13-13-14-15
G732-30 M06	30	23	15	13,5	9,5	12	2	M06	16-20-30-40-50	15-16-18-20-22
G732-30 M08	30	23	15	13,5	9,5	12	2	M08	16-20-30-40-50	20-22-25-28-31
G732-30 M10	30	23	15	13,5	9,5	12	2	M10	20-30-40-50-60	25-30-36-43-49
G732-40 M06	40,5	29,5	15,5	18,5	11	12	3	M06	16-20-30-40-50	24-26-28-30-32
G732-40 M08	40,5	29,5	15	18,5	11	12	3	M08	16-20-30-40-50	28-31-34-37-40
G732-40 M10	40,5	29,5	17	18,5	11	12	3	M10	16-20-30-40-50-60	35-38-43-48-53-59
G732-40 M12	40,5	29,5	21	18,5	11	12	3	M12	20-30-40	47-54-61
G732-50 M06	52	32,5	20,5	21,5	11	14,5	2,5	M06	16-20-30-40-50	42-43-45-47-49
G732-50 M08	52	32,5	20,5	21,5	11	14,5	2,5	M08	16-20-30-40-50-60	49-51-54-57-60-64
G732-50 M10	52	32,5	20,5	21,5	11	14,5	2,5	M10	16-20-30-40-50-60	55-58-63-68-72-77
G732-50 M12	52	32,5	20,5	21,5	11	14,5	2,5	M12	20-30-40-50-60	70-77-83-90-97
G732-60 M08	59	40	23	25	15	24	4	M08	16-20-30-40-50-60	73-76-79-81-85
G732-60 M10	59	40	23	25	15	24	4	M10	16-20-30-40-50-60	77-79-84-89-94-100
G732-60 M12	59	40	23	25	15	24	4	M12	20-30-40-50-60	91-97-104-111-119
G732-60 M14	59	40	23	25	15	24	4	M14	30-40-50	111-123-132
G732-80 M10	79	41	30	24	17	21	3	M10	20-30-40-50-60	100-105-110-115-120
G732-80 M12	79	41	30	24	17	21	3	M12	20-30-40-50-60	110-117-127-135-142
G732-80 M14	79	41	30	24	17	21	3	M14	20-30-40-50	120-131-145-182
G732-80 M16	79	41	30	24	17	21	3	M16	25-30-40-50	130-138-150-162

ART. G733

4-LOBE HANDWHEEL WITH SMOOTH HOLE INSERT

MATERIAL:

Reinforced polyamide.
Oils and greases resistant.

SURFACE:

Satin.

COLOUR:

Black (RAL 9011).

MAIN INSERT:

Zinc plated steel blind bored bush with H7 tolerance.
(*) Brass blind bored bush with H7 tolerance.

Bore not remachinable.



SPECIAL REQUESTS:

- It is possible to supply the inserts with d1 diameter by customer design, on request and for quantities.
- It is possible to supply the inserts in different materials, on request and for quantities.
- It is possible to supply colours as shown in the table at page 19, on request and for quantities.

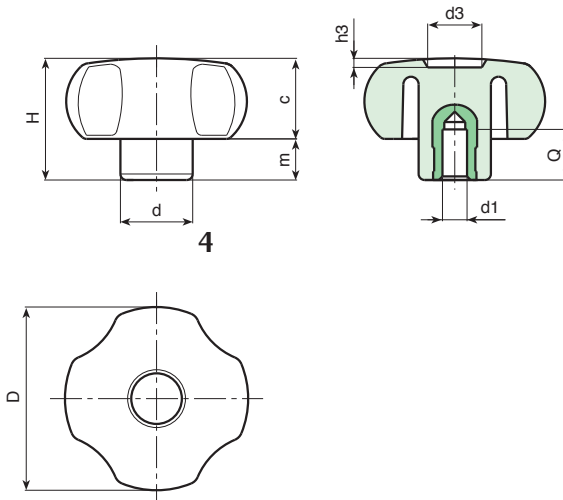

Art.	D	H	d	c	m	d3	h3	dm	d1 H7	Q	Weight (gr)
G733-30 D06	30	23	15	13,5	9,5	12,5	2	-	(*) 06	15	16
G733-30 D08	30	23	15	13,5	9,5	12,5	2	-	(*) 08	15	17
G733-40 D06	41	29,5	16	18,5	11	12	3	-	(*) 06	15	24
G733-40 D08	41	29,5	16	18,5	11	12	3	-	(*) 08	15	28
G733-40 D10	41	29,5	16	18,5	11	12	3	-	(*) 10	15	30
G733-50 D05	52	33	21	21,5	11,5	15	2,5	12	05 H9	18	60
G733-50 D10	52	33	21	21,5	11,5	15	2,5	12	10	18	60
G733-60 D05	59	40	23	24,5	15,5	24	4	12	05 H9	18	90
G733-60 D12	59	40	23	24,5	15,5	24	4	12	12	16	90
G733-80 D05	79	41	30,5	24	17	21	3	18	05 H9	24	165
G733-80 D12	79	41	30,5	24	17	21	3	18	12	24	140

It's possible to increase the hole, by boring, until dm.

ART. G734

4-LOBE HANDWHEEL WITH ELONGATED HUB AND THREADED INSERT

MATERIAL:

Reinforced polyamide.
Oils and greases resistant.

SURFACE:

Satin.

COLOUR:

Black (RAL 9011).

MAIN INSERT:

Brass blind threaded bush.

SPECIAL REQUESTS:

- It is possible to supply the inserts with different threads, on request and for quantities.
- It is possible to supply the inserts in different materials, on request and for quantities.
- It is possible to supply the handwheels with hubs to drawing, on request and for quantities.

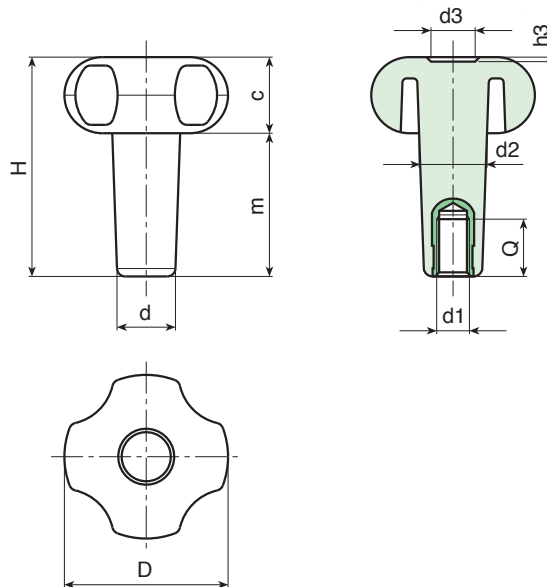

Art.	D	H	m	d	c	d2	d3	h3	d1	Q	Weight (gr)
G734-30 T25 M06	30	37,5	23,5	13,5	14	14,5	12	2	M06	10	15
G734-30 T35 M06	30	47	33,5	13,5	14	15	12	2	M06	16	16
G734-30 T35 M08	30	47	33,5	13,5	14	15	12	2	M08	21	17
G734-40 T35 M10	41	54	35	16,5	19	17	12	3	M10	15	30
G734-40 T66 M06	41	85	66	16,5	19	18	12	3	M06	18	35
G734-50 T40 M08	52	61	39	17,5	22	19	14	2,5	M08	15	47
G734-50 T40 M10	52	61	39	17,5	22	19	14	2,5	M10	15	49
G734-50 T50 M08	52	71	49	18	22	20,5	14	2,5	M08	15	55
G734-50 T50 M10	52	71	49	18	22	20,5	14	2,5	M10	15	56
G734-50 T60 M10	52	80	58	18	22	21	14	2,5	M10	15	62
G734-60 T60 M08	59	83	58	23	25	24	24	4	M08	21	91
G734-60 T60 M10	59	83	58	23	25	24	24	4	M10	15	91
G734-60 T60 M12	59	83	58	23	25	24	24	4	M12	21	96
G734-60 T80 M08	59	103	78	23	25	24	24	4	M08	21	105
G734-60 T80 M10	59	103	78	23	25	24	24	4	M10	15	104
G734-60 T80 M12	59	103	78	23	25	24	24	4	M12	21	107

**G-LOCKING
HANDWHEELS**

ROLLMEX

ART. G735

4-LOBE HANDWHEEL WITH ELONGATED HUB AND THREADED STUD

MATERIAL:

Reinforced polyamide.
Oils and greases resistant.

SURFACE:

Satin.

COLOUR:

Black (RAL 9011).

MAIN INSERT:

Zinc plated steel threaded stud.



SPECIAL REQUESTS:

- It is possible to supply the inserts with different lengths, on request and for quantities.
- It is possible to supply the inserts with different threads, on request and for quantities.
- It is possible to supply the inserts in different materials, on request and for quantities.
- It is possible to supply the handwheels with hubs to drawing, on request and for quantities.

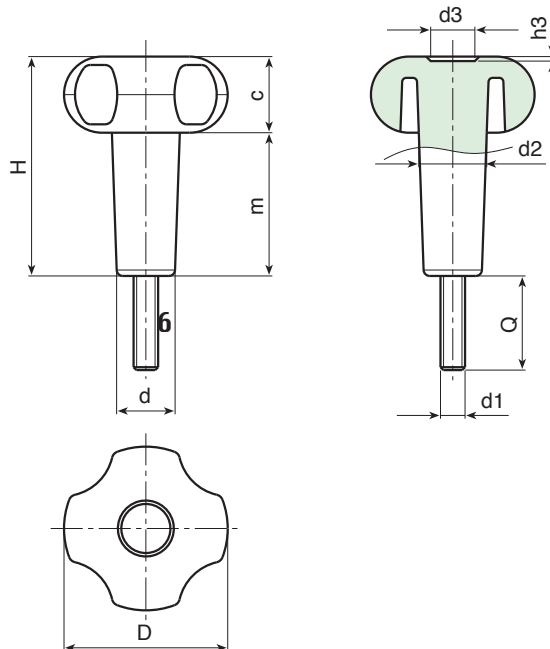

Art.	D	H	m	d	c	d2	d3	h3	d1	Q	Weight (gr)
G735-30 T35 M06	30	47	33,5	13,5	14	15	12	2	M06	15	23
G735-30 T35 M08	30	47	33,5	13,5	14	15	12	2	M08	30	36
G735-40 T35 M08	41	54	35	16,5	19	17	12	3	M08	20-30-40	47-49-53
G735-40 T35 M10	41	54	35	16,5	19	17	12	3	M10	15	54
G735-50 T40 M08	52	61	39	17,5	22	19	14	2,5	M08	15-20-30	64-67-69
G735-50 T40 M10	52	61	39	17,5	22	19	14	2,5	M10	15-20-30-40	74-77-79-82
G735-50 T50 M08	52	71	49	18	22	20,5	14	2,5	M08	30	75
G735-50 T60 M08	52	80	58	18	22	21	14	2,5	M08	30	86
G735-60 T60 M08	59	83	58	23	25	24	24	4	M08	20	115
G735-60 T60 M10	59	83	58	23	25	24	24	4	M10	30-40	130-138
G735-60 T80 M10	59	103	78	23	25	24	24	4	M10	50	150

ART. G650

6-LOBE HANDWHEEL WITH PLUG AND THREADED INSERT

MATERIAL:

Reinforced polyamide.
Oils and greases resistant.

SURFACE:

Satin.

COLOUR:

Black (RAL 9011).

CENTRAL CAP:

Grey polyamide (RAL 7035 code 13).

ALTERNATIVE CAP COLOUR:

Orange (RAL 2004 code 02).
Blue (RAL 5015 code 07).
Yellow (RAL 1021 code 10).
Red (RAL 3000 code 16).
Green (RAL 6024 code 17).
Black (RAL 9011 code 01).

MAIN INSERT:

Brass right through threaded bush.



SPECIAL REQUESTS:

- It is possible to supply the inserts in different materials, on request and for quantities.
- It is possible to supply the handwheel with colours as shown in the table at page 19, on request and for quantities.

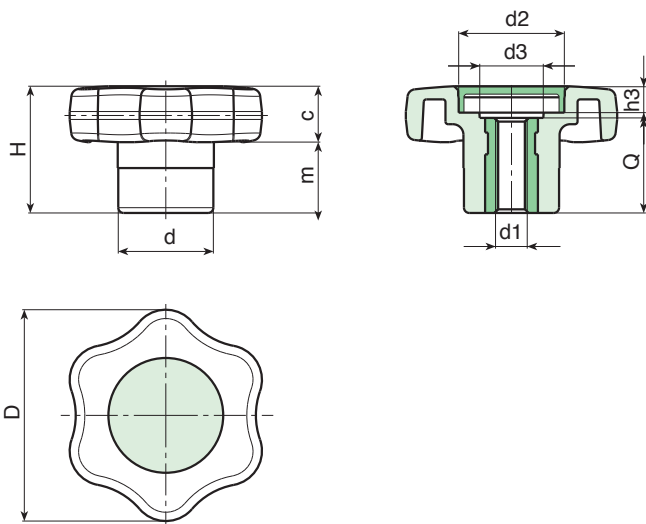

PAD PRINTING SERVICE:

- Upon request and for special quantities caps can be supplied with customized pad printing.



Art.	D	H	d	m	c	d2	d3	h3	d1	Q	Weight (gr)
G650-40 M06	40	24	18	10,5	13,5	20	13	6	M6	18	18
G650-40 M08	40	24	18	10,5	13,5	20	13	6	M8	18	19
G650-40 M10	40	24	18	10,5	13,5	20	13	6	M10	18	20

**G-LOCKING
HANDWHEELS**

ROLLMEX

ART. G651

6-LOBE HANDWHEEL WITH PLUG AND THREADED STUD

MATERIAL:

Reinforced polyamide.
Oils and greases resistant.

SURFACE:

Satin.

COLOUR:

Black (RAL 9011).

CENTRAL CAP:

Grey polyamide (RAL 7035 code 13).

ALTERNATIVE CAP COLOUR:

Orange (RAL 2004 code 02).
Blue (RAL 5015 code 07).
Yellow (RAL 1021 code 10).
Red (RAL 3000 code 16).
Green (RAL 6024 code 17).
Black (RAL 9011 code 01).

MAIN INSERT:

Zinc plated steel threaded stud.



SPECIAL REQUESTS:

- It is possible to supply the inserts with different lengths, on request and for quantities.
- It is possible to supply the inserts in different materials, on request and for quantities.
- It is possible to supply the handwheel with colours as shown in the table at page 19, on request and for quantities.

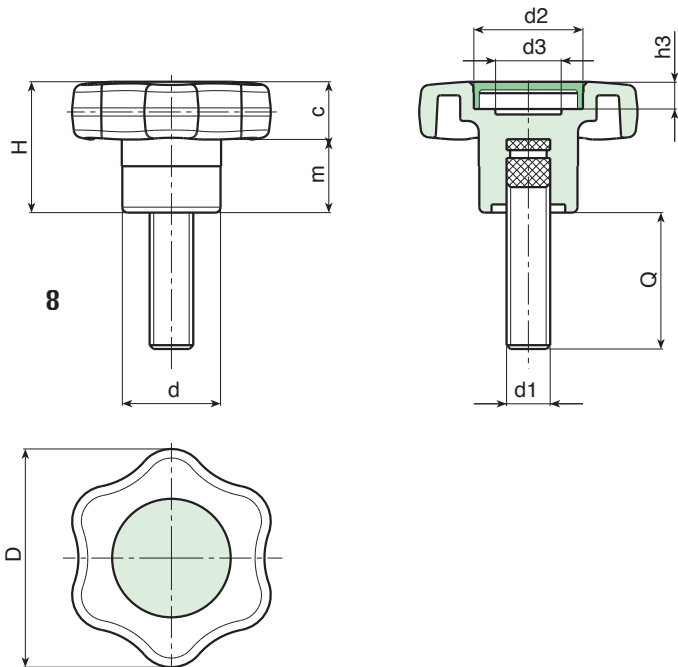

PAD PRINTING SERVICE:

- Upon request and for special quantities caps can be supplied with customized pad printing.

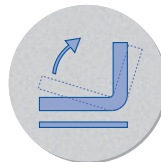

Art.	D	H	d	m	c	d2	d3	h3	d1	Q	Weight (gr)
G651-40 M06	40	24	18	10,5	13,5	20	13	6	M6	16-20-30-40	17-17,5-19-21
G651-40 M08	40	24	18	10,5	13,5	20	13	6	M8	20-30-40	20-23-27
G651-40 M10	40	24	18	10,5	13,5	20	13	6	M10	20-30-40-50	24-29-34-39

ART. G791

CYLINDRICAL HANDWHEEL WITH THREADED INSERT

MATERIAL:

Reinforced polyamide.
Oils and greases resistant.

SURFACE:

Satin.

COLOUR:

Black (RAL 9011).

MAIN INSERT:

Brass blind threaded bush.

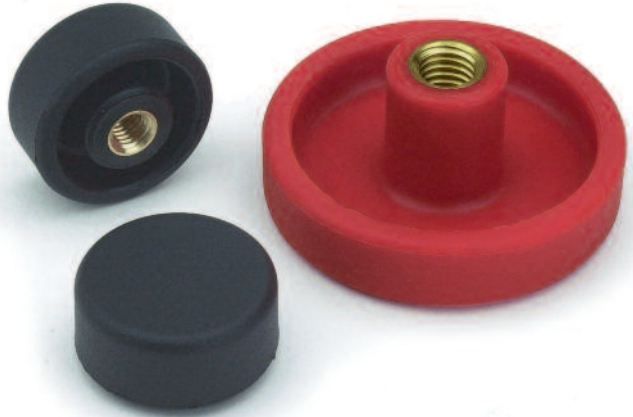

SPECIAL REQUESTS:

- It is possible to supply the inserts in different materials, on request and for quantities.
- It is possible to supply colours as shown in the table at page 19, on request and for quantities.

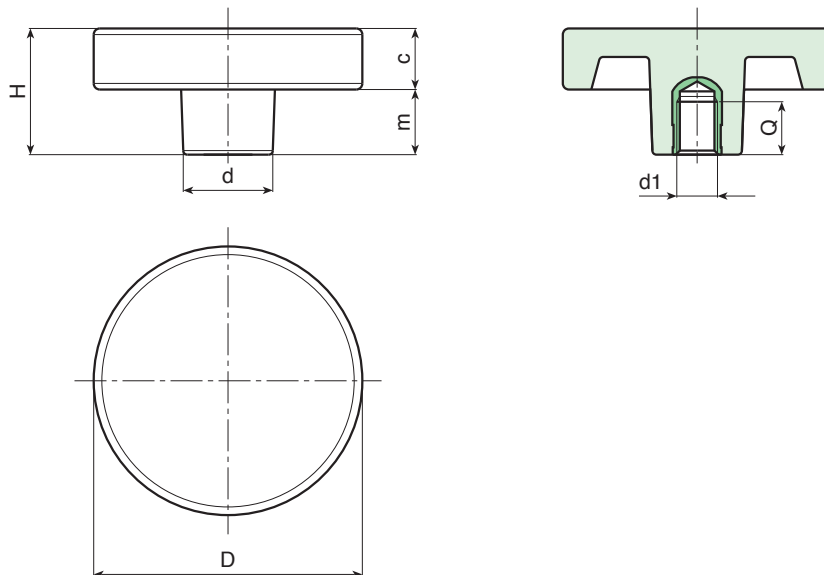

Art.	D	H	d	c	m	d1	Q	Weight (gr)
G791-36 M06	36	17	18	16	1	M06	10	18
G791-36 M08	36	17	18	16	1	M08	15	18
G791-36 M10	36	18	18	16	2	M10	14	19
G791-50 M08	50	30,5	22	15	15,5	M08	15	35
G791-50 M10	50	30,5	22	15	15,5	M10	14	36
G791-50 M12	50	30,5	22	15	15,5	M12	18	40
G791-66 M08	65	30	22	15	15	M08	15	52
G791-66 M10	65	30	22	15	15	M10	14	55
G791-66 M12	65	30	22	15	15	M12	18	58
G791-66 M14	65	30	22	15	15	M14	19	60

ART. G792

CYLINDRICAL HANDWHEEL WITH SMOOTH HOLE INSERT

MATERIAL:

Reinforced polyamide.
Oils and greases resistant.

SURFACE:

Satin.

COLOUR:

Black (RAL 9011).

MAIN INSERT:

Zinc plated steel blind bored bush
with H7 tolerance.



SPECIAL REQUESTS:

- It is possible to supply the inserts with d1 diameter by customer design, on request and for quantities.
- It is possible to supply the inserts in different materials, on request and for quantities.
- It is possible to supply colours as shown in the table at page 19, on request and for quantities.

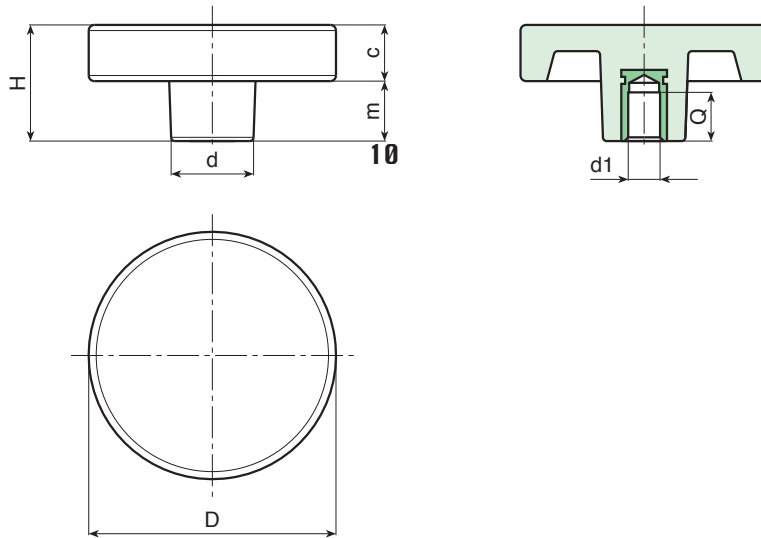

Art.	D	H	d	c	m	dm	d1 H7	Q	Weight (gr)
G792-50 D08	50	30,5	22	15	15	12	8	20	62
G792-66 D05	65	30	22	15	15	12	05 H9	20	80
G792-66 D12	65	30	22	15	15	12	12	20	75

It's possible to increase the hole, by boring, until **dm**.

ART. G793

CYLINDRICAL HANDWHEEL WITH THREADED STUD

MATERIAL:

Reinforced polyamide.
Oils and greases resistant.

SURFACE:

Satin.

COLOUR:

Black (RAL 9011).

MAIN INSERT:

Zinc plated steel threaded stud.



SPECIAL REQUESTS:

- It is possible to supply the inserts with different lengths, on request and for quantities.
- It is possible to supply the inserts in different materials, on request and for quantities.
- It is possible to supply colours as shown in the table at page 19, on request and for quantities.

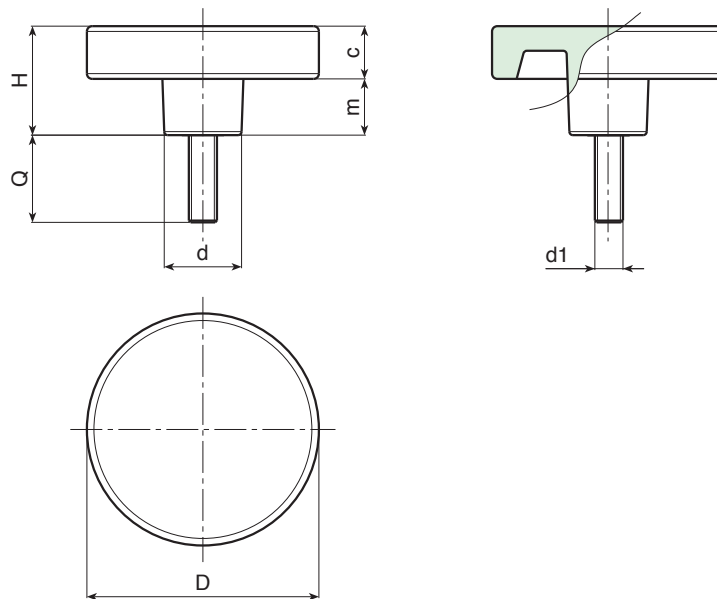

Art.	D	H	d	c	m	d1	Q	Weight (gr)
G793-36 M06	36	17	18	16	1	M06	16-20-30	16-17-20
G793-36 M08	36	17	18	16	1	M08	16-20-30-40	18-21-25-30
G793-36 M10	36	18	18	16	2	M10	20-30-40	27-34-42
G793-50 M08	50	30,5	22	15	15,5	M08	20-30	40-44
G793-50 M10	50	30,5	22	15	15,5	M10	20-30-40	46-53-61
G793-50 M12	50	30,5	22	15	15,5	M12	30-40	68-80
G793-66 M08	65	30	22	15	15	M08	20-30	59-63
G793-66 M10	65	30	22	15	15	M10	25-50	68-80
G793-66 M12	65	30	22	15	15	M12	25-50	80-97

ART. G794

KNOB WITH THREADED INSERT

MATERIAL:

Reinforced polyamide.
Oils and greases resistant.

SURFACE:

Satin.

COLOUR:

Black (RAL 9011).

MAIN INSERT:

Brass blind threaded bush.



SPECIAL REQUESTS:

- It is possible to supply the inserts in different materials, on request and for quantities.
- It is possible to supply colours as shown in the table at page 19, on request and for quantities.

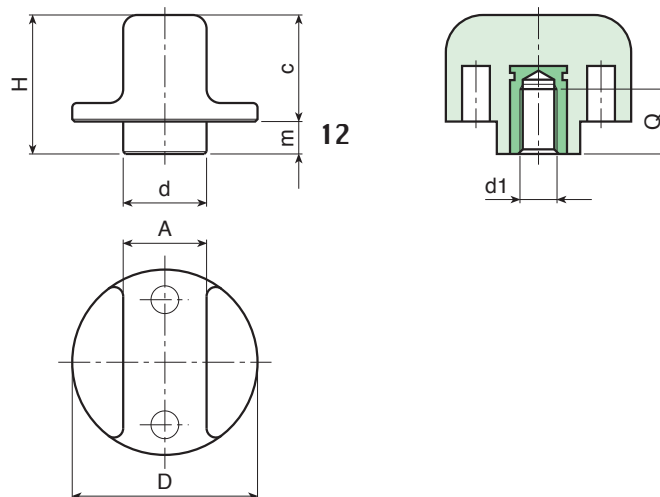

Art.	D	H	d	A	c	m	d1	Q	Weight (gr)
G794-25 M05	25	20	12	10	15	5	M05	11	8
G794-25 M06	25	20	12	10	15	5	M06	9	9
G794-25 M08	25	20	12	10	15	5	M08	8	10
G794-40 M08	40	30	18	18	22,5	7,5	M08	15	25
G794-40 M10	40	30	18	18	22,5	7,5	M10	14	26
G794-40 M12	40	30	18	18	22,5	7,5	M12	14	28

ART. G795

KNOB WITH THREADED STUD

MATERIAL:

Reinforced polyamide.
Oils and greases resistant.

SURFACE:

Satin.

COLOUR:

Black (RAL 9011).

MAIN INSERT:

Zinc plated steel threaded stud.

SPECIAL REQUESTS:

- It is possible to supply the inserts with different lengths, on request and for quantities.
- It is possible to supply the inserts in different materials, on request and for quantities.
- It is possible to supply colours as shown in the table at page 19, on request and for quantities.

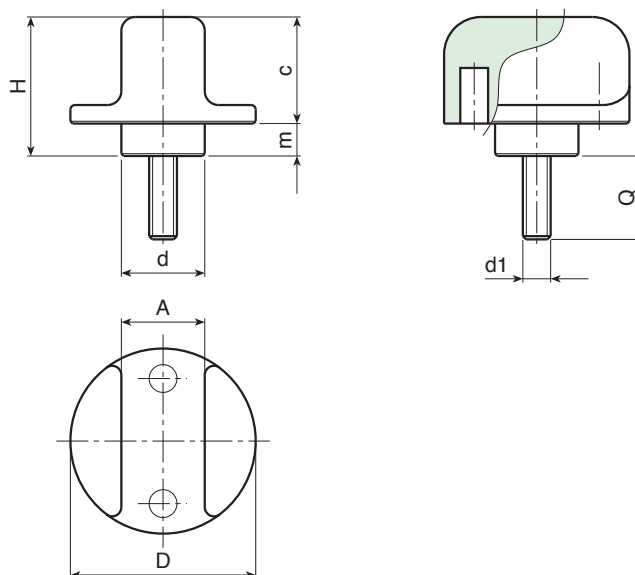

Art.	D	H	d	A	c	m	d1	Q	Weight (gr)
G795-25 M05	25	20	12	10	15	5	M05	16-20-25	9-10-12
G795-25 M06	25	20	12	10	15	5	M06	16-20-30-40	10,5-11-13-14,5
G795-25 M08	25	20	12	10	15	5	M08	16-20-30-40	18-19-22-25
G795-40 M08	40	30	18	18	22,5	7,5	M08	16-20-30-40	33-34-37-40
G795-40 M10	40	30	18	18	22,5	7,5	M10	20-30-40	41-46-51

ART. G796

KNOB WITH THREADED INSERT

MATERIAL:

Reinforced polyamide.
Oils and greases resistant.

SURFACE:

Satin.

COLOUR:

Black (RAL 9011).

MAIN INSERT:

Brass blind threaded bush.

SPECIAL REQUESTS:

- It is possible to supply the inserts in different materials, on request and for quantities.
- It is possible to supply colours as shown in the table at page 19, on request and for quantities.

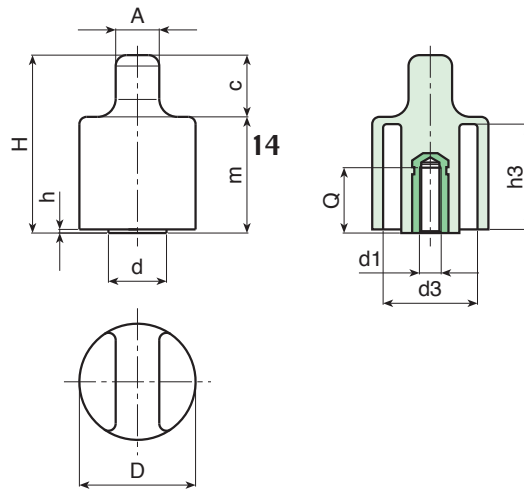
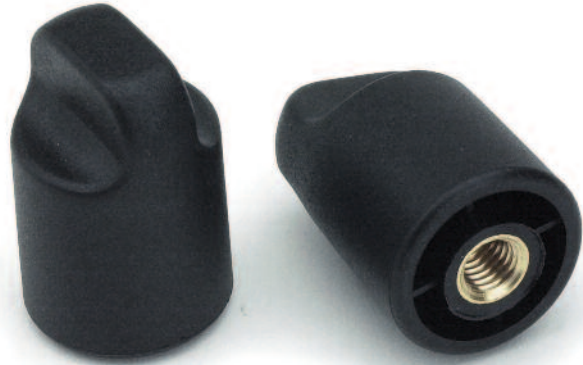

Art.	D	H	d	A	c	m	h	h3	d3	d1	Q	Weight (gr)
G796-32 M06	32	49	16	12	15	34	1	29	25,5	M06	16	33
G796-32 M08	32	49	16	12	15	34	1	29	25,5	M08	14	35
G796-32 M10	32	49	16	12	15	34	1	29	25,5	M10	13	36

ART. G797

KNOB WITH THREADED INSERT

MATERIAL:

Reinforced polyamide.
Oils and greases resistant.

SURFACE:

Satin.

COLOUR:

Black (RAL 9011).

MAIN INSERT:

Zinc plated steel threaded stud.

SPECIAL REQUESTS:

- It is possible to supply the inserts in different materials, on request and for quantities.
- It is possible to supply colours as shown in the table at page 19, on request and for quantities.

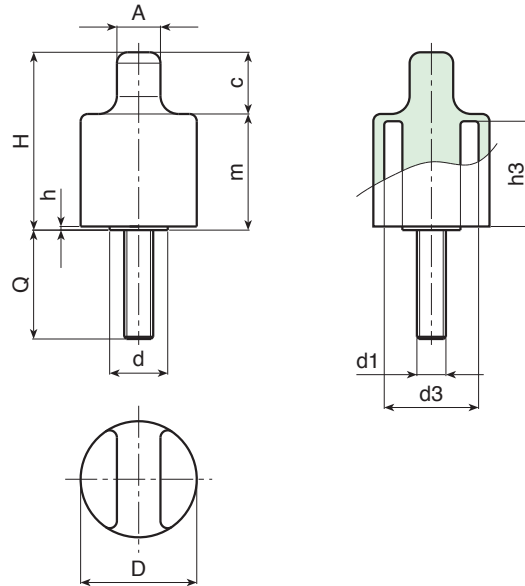

Art.	D	H	d	A	c	m	h	h3	d3	d1	Q	Weight (gr)
G797-32 M06	32	49	16	12	15	34	1	29	25,5	M06	16-20	33-37
G797-32 M08	32	49	16	12	15	34	1	29	25,5	M08	16-32	42-45
G797-32 M10	32	49	16	12	15	34	1	29	25,5	M10	20-40	51-57
G797-32 M12	32	49	16	12	15	34	1	29	25,5	M12	20	59

ART. G798

ELONGATED KNOB WITH THREADED INSERT

MATERIAL:

Reinforced polyamide.
Oils and greases resistant.

SURFACE:

Satin.

COLOUR:

Black (RAL 9011).

MAIN INSERT:

Brass blind threaded bush.



SPECIAL REQUESTS:

- It is possible to supply the inserts in different materials, on request and for quantities.
- It is possible to supply colours as shown in the table at page 19, on request and for quantities.

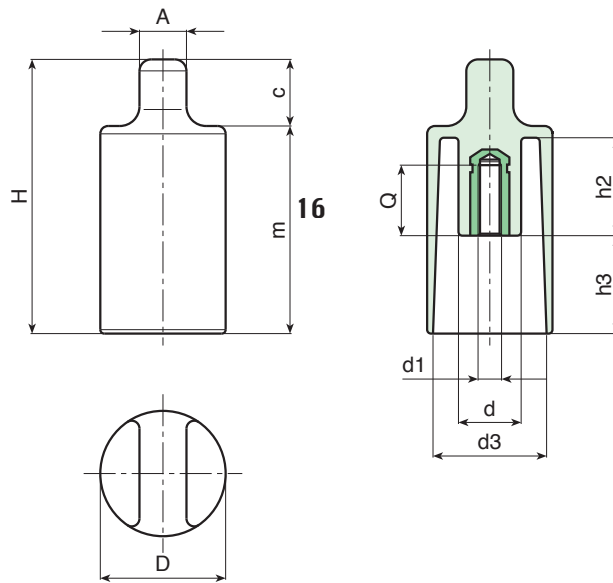

Art.	D	H	d	A	c	m	h2	h3	d3	d1	Q	Weight (gr)
G798-32 M06	32	69	12	12	15	54	25	26	28	M06	22	32
G798-32 M08	32	69	12	12	15	54	25	26	28	M08	20	35

ART. G799

ELONGATED KNOB WITH THREADED STUD

MATERIAL:

Reinforced polyamide.
Oils and greases resistant.

SURFACE:

Satin.

COLOUR:

Black (RAL 9011).

MAIN INSERT:

Zinc plated steel threaded stud.

SPECIAL REQUESTS:



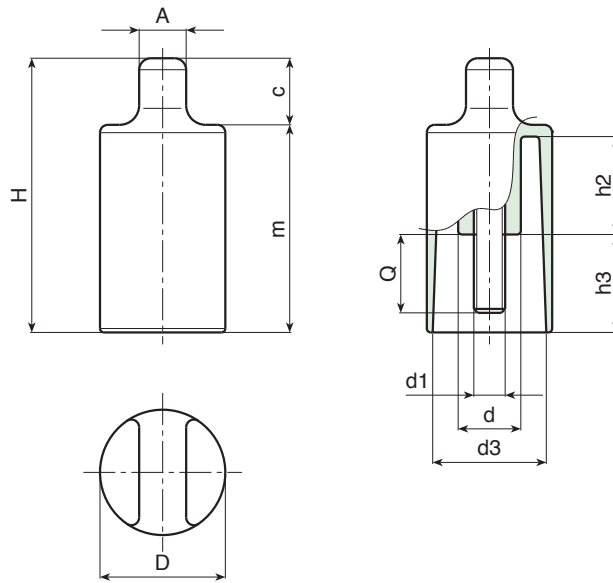











- It is possible to supply the inserts in different materials, on request and for quantities.
- It is possible to supply colours as shown in the table at page 19, on request and for quantities.







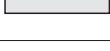









Art.	D	H	d	A	c	m	h2	h3	d3	d1	Q	Weight (gr)
G799-32 M06	32	69	12	12	15	54	25	26	29	M06	16	40
G799-32 M08	32	69	12	12	15	54	25	26	29	M08	10-16	42-48

COLOUR CHART

R A L

COLOUR		RAL	CODE
Black		9011	01
Orange		2004	02
Orange		2011	03
White		9010	04
Blue		5002	05
Blue		5005	06
Blue		5015	07
Blue		5018	19
Blue		5019	21
Blue		5010	22
Yellow		1007	09
Yellow		1021	10
Grey		7024	12
Grey		7035	13
Red		3000	16
Green		6024	17

O T H E R C O L O U R S

COLOUR		REF.	CODE
White		-	52
Blue		-	53
Blue		pant. 645 U	54
Blue		pant. 300	55
Grey		-	57
Grey		-	59
Grey		NCS 7500	60
Red		-	64
Red		-	65
Natural		-	66
Green		-	70
Brown		-	71
Cream		-	72
Violet		-	73

18



WWW.ROLLMEX.FI

ROLLMEX Oy

Takojankatu 4 - 33540 TAMPERE
Push. 010-6661122 - Fax 03-3640072
tamper@rollmex.fi

Karjalankatu 21 - 15140 LAHTI
Push. 010-6661121 - Fax 03-7511026
lahti@rollmex.fi

AUTHORISED RESELLER