

**F – FAMILY
SOLID
LOCKING
HANDWHEELS**



 **ROLLMEX**

**F – SOLID LOCKING
HANDWHEELS**

© ROLLMEX - Reproduction prohibited



ART. F175

6-LOBE HANDWHEEL WITH THREADED FEMALE INSERT

MATERIAL:

Reinforced polyamide.
Oils and greases resistant.

SURFACE:

Satin.

COLOUR:

Black (RAL 9011).

MAIN INSERT:

Brass blind threaded bush.

SPECIAL REQUESTS:

- It is possible to supply the inserts in different materials, on request and for quantities.
- It is possible to supply colours as shown in the table at page 23, on request and for quantities.

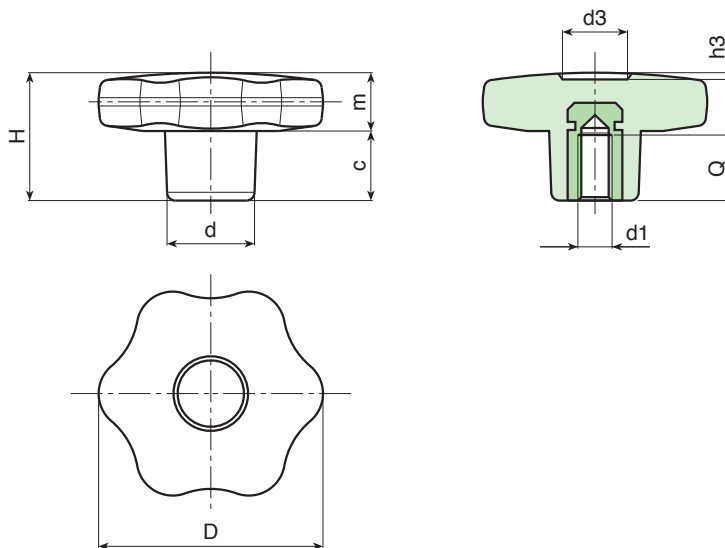

Art.	D	H	d	c	m	d3	h3	Q	d1	Weight (gr)
F175-30 M04	30	22	15	11	11	9	1,5	7	M4	11,5
F175-30 M05	30	22	15	11	11	9	1,5	14	M5	11,5
F175-30 M06	30	22	15	11	11	9	1,5	10	M6	12
F175-30 M08	30	22	15	11	11	9	1,5	14	M8	13,5
F175-30 M10	30	22	15	11	11	9	1,5	14	M10	14
F175-40 M05	40	24,5	17	12	12,5	12	1	14	M5	22
F175-40 M06	40	24,5	17	12	12,5	12	1	16	M6	22
F175-40 M08	40	24,5	17	12	12,5	12	1	14	M8	21,5
F175-40 M10	40	24,5	17	12	12,5	12	1	14	M10	21
F175-50 M06	50	29	20	14	15	14,5	1,5	16	M6	36
F175-50 M08	50	29	20	14	15	14,5	1,5	14	M8	36
F175-50 M10	50	29	20	14	15	14,5	1,5	14	M10	37
F175-50 M12	50	29	20	14	15	14,5	1,5	18	M12	39
F175-60 M08	60	34	24	16	18	18	1,5	19	M8	59
F175-60 M10	60	34	24	16	18	18	1,5	21	M10	59
F175-60 M12	60	34	24	16	18	18	1,5	18	M12	62
F175-60 M14	60	34	24	16	18	18	1,5	19	M14	63

ART. F 176

6-LOBE HANDWHEEL WITH SMOOTH HOLE

MATERIAL:

Reinforced polyamide.
Oils and greases resistant.

SURFACE:

Satin.

COLOUR:

Black (RAL 9011).

MAIN INSERT:

Brass blind bored bush with H7 tolerance.
(*) Zinc plated steel blind bored bush with H7 tolerance.



SPECIAL REQUESTS:

- It is possible to supply the inserts with d1 diameter by customer design, on request and for quantities.
- It is possible to supply the inserts in different materials, on request and for quantities.
- It is possible to supply colours as shown in the table at page 23, on request and for quantities.

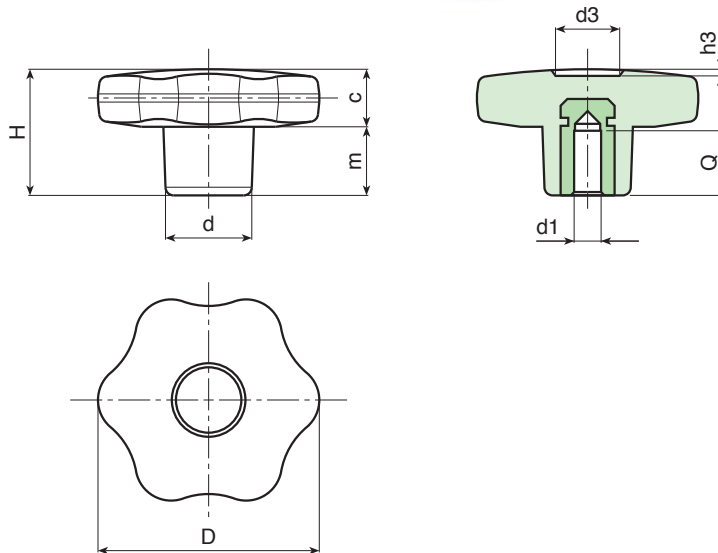

Art.	D	H	d	c	m	d3	h3	Q	d1 H7	Weight (gr)
F176-30 D06	30	22	15	11	11	9	1,5	15	06	17
F176-30 D08	30	22	15	11	11	9	1,5	15	08	19
F176-40 D06	40	24,5	17	12	12,5	12	1	15	06	24
F176-40 D08	40	24,5	17	12	12,5	12	1	15	08	26
F176-40 D10	40	24,5	17	12	12,5	12	1	17	10	28
F176-50 D06	50	29	20	14	15	14,5	1,5	15	06	39
F176-50 D08	50	29	20	14	15	14,5	1,5	15	08	41
F176-50 D10	50	29	20	14	15	14,5	1,5	17	10	42
F176-60 D08	60	34	24	16	18	18	1,5	18	(*) 08	78
F176-60 D10	60	34	24	16	18	18	1,5	25	(*) 10	73
F176-60 D12	60	34	24	16	18	18	1,5	22	(*) 12	75

ART. F177

6-LOBE HANDWHEEL WITH THREADED THROUGH FEMALE INSERT

MATERIAL:

Reinforced polyamide.
Oils and greases resistant.

SURFACE:

Satin.

COLOUR:

Black (RAL 9011).

MAIN INSERT:

Brass right through threaded bush.



SPECIAL REQUESTS:

- It is possible to supply the inserts in different materials, on request and for quantities.
- It is possible to supply colours as shown in the table at page 23, on request and for quantities.

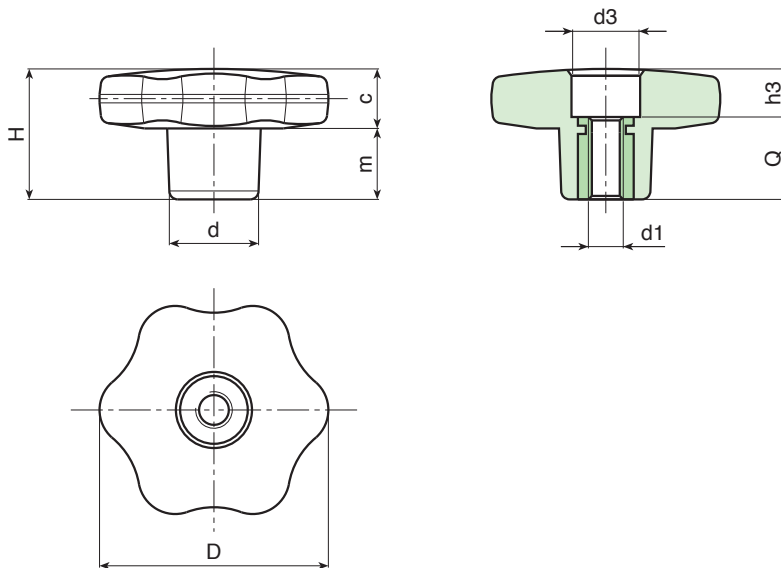

Art.	D	H	d	c	m	d3	h3	Q	d1	Weight (gr)
F177-30 M05	30	22	15	11	11	11	4	18	M5	12
F177-30 M06	30	22	15	11	11	11	4	18	M6	13
F177-30 M08	30	22	15	11	11	11	4	18	M8	13
F177-30 M10	30	22	15	11	11	11	4	18	M10	14
F177-40 M06	40	24,5	17	12	12,5	12	6	18	M6	20
F177-40 M08	40	24,5	17	12	12,5	12	6	18	M8	21
F177-40 M10	40	24,5	17	12	12,5	12	6	18	M10	22
F177-50 M06	50	29	20	14	15	14	11	18	M6	33
F177-50 M08	50	29	20	14	15	14	11	18	M8	34
F177-50 M10	50	29	20	14	15	14	11	18	M10	35
F177-50 M12	50	29	20	14	15	14	11	18	M12	35
F177-60 M08	60	34	24	16	18	15	16	18	M8	54
F177-60 M10	60	34	24	16	18	15	16	18	M10	55
F177-60 M12	60	34	24	16	18	15	16	18	M12	55
F177-60 M14	60	34	24	16	18	15	16	18	M14	56

ART. F178

6-LOBE HANDWHEEL WITH THREADED STUD

MATERIAL:

Reinforced polyamide.
Oils and greases resistant.

SURFACE:

Satin.

COLOUR:

Black (RAL 9011).

MAIN INSERT:

Zinc plated steel threaded stud.



SPECIAL REQUESTS:

- It is possible to supply the inserts with different lengths, on request and for quantities.
- It is possible to supply the inserts in different materials, on request and for quantities.
- It is possible to supply colours as shown in the table at page 23, on request and for quantities.

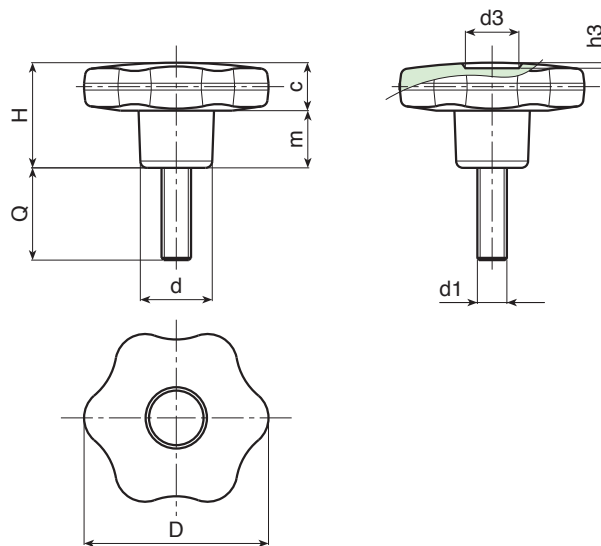

Art.	D	H	d	c	m	d3	h3	d1	Q	Weight (gr)
F178-30 M05	30	22	15	11	11	9	1,5	M5	16-20-30	14-15-16
F178-30 M06	30	22	15	11	11	9	1,5	M6	16-20-30	16-17-18
F178-30 M08	30	22	15	11	11	9	1,5	M8	16-20-30-40	19-21-25-28
F178-30 M10	30	22	15	11	11	9	1,5	M10	20-30-40	28-33-39
F178-40 M06	40	24,5	17	12	12,5	12	1	M6	16-20-30-40	25-25-27-28
F178-40 M08	40	24,5	17	12	12,5	12	1	M8	20-30-40-50	30-33-36-39
F178-40 M10	40	24,5	17	12	12,5	12	1	M10	20-30-40-50	37-41-45-49
F178-50 M08	50	29	20	14	15	14,5	1,5	M8	20-30-40	49-52-55
F178-50 M10	50	29	20	14	15	14,5	1,5	M10	20-30-40-50	55-60-61-64
F178-50 M12	50	29	20	14	15	14,5	1,5	M12	20-30-40-50	63-67-72-77
F178-60 M08	60	34	24	16	18	18	1,5	M8	20-30-40	68-71-74
F178-60 M10	60	34	24	16	18	18	1,5	M10	20-30-40-50	74-80-85-88
F178-60 M12	60	34	24	16	18	18	1,5	M12	20-30-40-50	95-102-109-116
F178-60 M14	60	34	24	16	18	18	1,5	M14	30-40-50	103-113-122

ART. F175 CIN

6-LOBE HANDWHEEL WITH STAINLESS STEEL THREADED FEMALE INSERT

INOX

MATERIAL:

Reinforced polyamide.
Oils and greases resistant.

SURFACE:

Satin.

COLOUR:

Black (RAL 9011).

MAIN INSERT:

Stainless steel blind threaded bush (AISI 303).

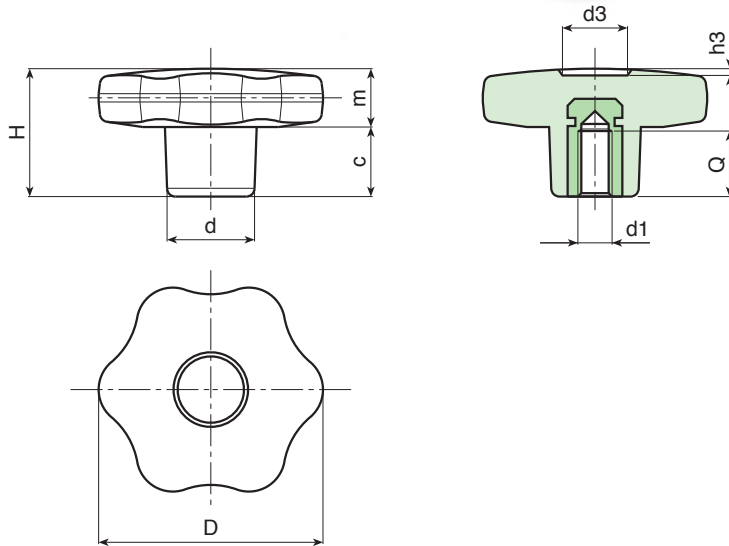

Art.	D	H	d	c	m	d3	h3	Q	d1	Weight (gr)
F175-30 M05 CIN	30	22	15	11	11	9	1,5	14	M5	13
F175-30 M06 CIN	30	22	15	11	11	9	1,5	10	M6	13
F175-30 M08 CIN	30	22	15	11	11	9	1,5	14	M8	13
F175-40 M06 CIN	40	24,5	17	12	12,5	12,5	1	16	M6	13
F175-40 M08 CIN	40	24,5	17	12	12,5	12	1	14	M8	13
F175-40 M10 CIN	40	24,5	17	12	12,5	12	1	14	M10	13
F175-50 M08 CIN	50	29	20	14	15	14,5	1,5	14	M8	13
F175-50 M10 CIN	50	29	20	14	15	14,5	1,5	14	M10	13
F175-60 M10 CIN	60	34	24	16	18	18	1,5	21	M10	13
F175-60 M12 CIN	60	34	24	16	18	18	1,5	18	M12	13

ART. F177 CIN

6-LOBE HANDWHEEL WITH STAINLESS STEEL THREADED THROUGH FEMALE INSERT

INOX

MATERIAL:

Reinforced polyamide.
Oils and greases resistant.

SURFACE:

Satin.

COLOUR:

Black (RAL 9011).

MAIN INSERT:

Stainless steel right through threaded bush (AISI 303).

SPECIAL REQUESTS:

- It is possible to supply colours as shown in the table at page 23, on request and for quantities.

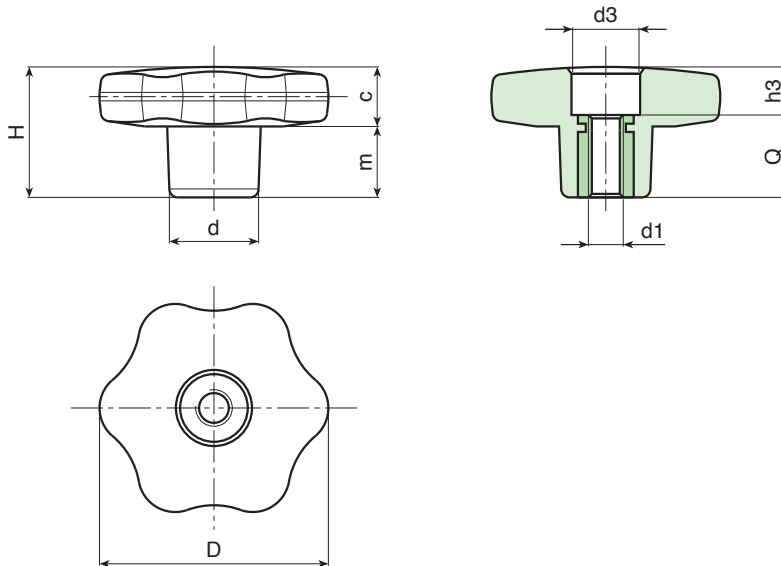

Art.	D	H	d	c	m	d3	h3	Q	d1	Weight (gr)
F177-30 M05 CIN	30	22	15	11	11	11	4	18	M5	14
F177-30 M06 CIN	30	22	15	11	11	11	4	18	M6	15
F177-30 M08 CIN	30	22	15	11	11	11	4	18	M8	14
F177-40 M06 CIN	40	24,5	17	12	12,5	12	6	18	M6	22
F177-40 M08 CIN	40	24,5	17	12	12,5	12	6	18	M8	21
F177-40 M10 CIN	40	24,5	17	12	12,5	12	6	18	M10	20
F177-50 M08 CIN	50	29	20	14	15	14	11	18	M8	37
F177-50 M10 CIN	50	29	20	14	15	14	11	18	M10	36
F177-50 M12 CIN	50	29	20	14	15	14	11	18	M12	36
F177-60 M10 CIN	60	34	24	16	18	15	16	18	M10	59
F177-60 M12 CIN	60	34	24	16	18	15	16	18	M12	59

ART. F178 CIN

6-LOBE HANDWHEEL WITH STAINLESS STEEL THREADED STUD

INOX

MATERIAL:

Reinforced polyamide.
Oils and greases resistant.

SURFACE:

Satin.

COLOUR:

Black (RAL 9011).

MAIN INSERT:

Stainless steel threaded stud (AISI 304).



SPECIAL REQUESTS:

- It is possible to supply the inserts with different lengths, on request and for quantities.
- It is possible to supply colours as shown in the table at page 23, on request and for quantities.

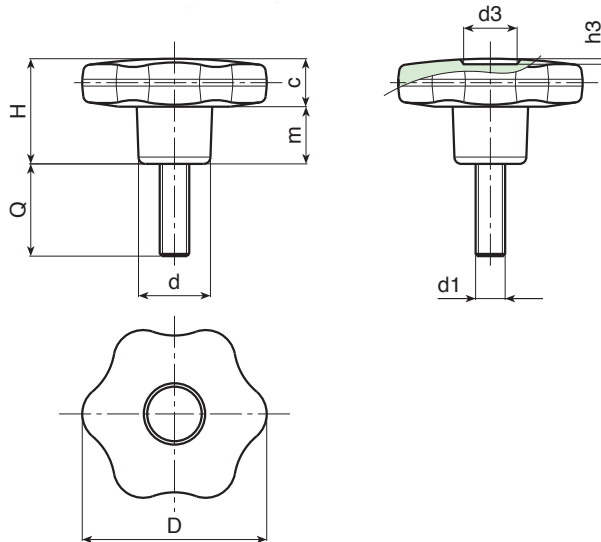

Art.	D	H	d	c	m	d3	h3	d1	Q	Weight (gr)
F178-30 M05 CIN	30	22	15	11	11	9	1,5	M5	20-40	18-20
F178-30 M06 CIN	30	22	15	11	11	9	1,5	M6	20-40	20-22
F178-30 M08 CIN	30	22	15	11	11	9	1,5	M8	20-30-40	24-28-32
F178-30 M10 CIN	30	22	15	11	11	9	1,5	M10	20-30-40	33-39-42
F178-40 M06 CIN	40	24,5	17	12	12,5	12	1	M6	20-40	26-31
F178-40 M08 CIN	40	24,5	17	12	12,5	12	1	M8	20-30-40	33-36-39
F178-40 M10 CIN	40	24,5	17	12	12,5	12	1	M10	20-30-40	40-44-49
F178-50 M08 CIN	50	29	20	14	15	14,5	1,5	M8	20-30-40	52-55-58
F178-50 M10 CIN	50	29	20	14	15	14,5	1,5	M10	20-30-40-50	59-63-64-67
F178-50 M12 CIN	50	29	20	14	15	14,5	1,5	M12	20-30-40-50	67-72-77-82
F178-60 M08 CIN	60	34	24	16	18	18	1,5	M8	20-30-40	70-73-77
F178-60 M10 CIN	60	34	24	16	18	18	1,5	M10	20-30-40-50	79-85-90-93
F178-60 M12 CIN	60	34	24	16	18	18	1,5	M12	20-30-40-50	101-108-115-123
F178-60 M14 CIN	60	34	24	16	18	18	1,5	M14	30-40-50	111-123-132

ART. F186

CROSS HANDWHEEL WITH THREADED FEMALE INSERT

MATERIAL:

Reinforced polyamide.
Oils and greases resistant.

SURFACE:

Satin.

COLOUR:

Black (RAL 9011).

MAIN INSERT:

Brass blind threaded bush.



SPECIAL REQUESTS:

- It is possible to supply the inserts in different materials, on request and for quantities.
- It is possible to supply colours as shown in the table at page 23, on request and for quantities.

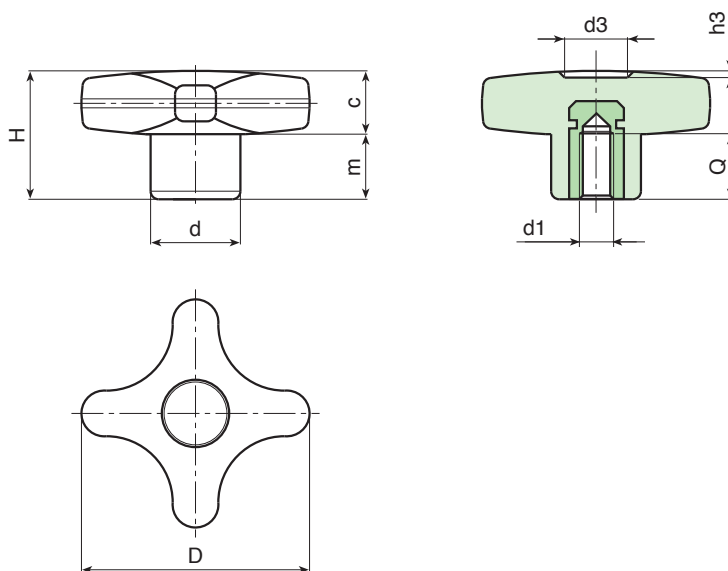

Art.	D	H	d	c	m	d3	h3	Q	d1	Weight (gr)
F186-32 M04	32	23	15	11	12	11	1,5	7	M4	11
F186-32 M05	32	23	15	11	12	11	1,5	14	M5	11,5
F186-32 M06	32	23	15	11	12	11	1,5	10	M6	12
F186-32 M08	32	23	15	11	12	11	1,5	14	M8	12,5
F186-32 M10	32	23	15	11	12	11	1,5	14	M10	13
F186-40 M05	40	24,5	16	12	12,5	13	1,5	14	M5	14
F186-40 M06	40	24,5	16	12	12,5	13	1,5	16	M6	15
F186-40 M08	40	24,5	16	12	12,5	13	1,5	14	M8	16
F186-40 M10	40	24,5	16	12	12,5	13	1,5	14	M10	17
F186-50 M06	50	29	20	14	15	14	2	16	M6	25
F186-50 M08	50	29	20	14	15	14	2	14	M8	26
F186-50 M10	50	29	20	14	15	14	2	14	M10	27
F186-50 M12	50	29	20	14	15	14	2	18	M12	29
F186-60 M08	60	34	24	15,5	18,5	18	2	19	M8	40
F186-60 M10	60	34	24	15,5	18,5	18	2	21	M10	43
F186-60 M12	60	34	24	15,5	18,5	18	2	18	M12	44
F186-60 M14	60	34	24	15,5	18,5	18	2	19	M14	47

ART. F187

CROSS HANDWHEEL WITH SMOOTH HOLE

MATERIAL:

Reinforced polyamide.
Oils and greases resistant.

SURFACE:

Satin.

COLOUR:

Black (RAL 9011).

MAIN INSERT:

Brass blind bored bush with H7 tolerance.
(*) Zinc plated steel blind bored bush with H7 tolerance.



SPECIAL REQUESTS:

- It is possible to supply the inserts with d1 diameter by customer design, on request and for quantities.
- It is possible to supply the inserts in different materials, on request and for quantities.
- It is possible to supply colours as shown in the table at page 23, on request and for quantities.

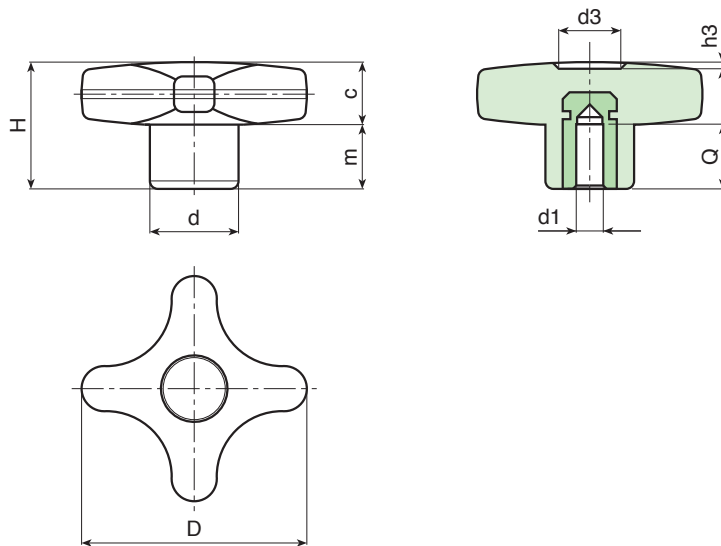

Art.	D	H	d	c	m	d3	h3	Q	d1 H7	Weight (gr)
F187-32 D06	32	23	15	11	12	11	1,5	15	06	13
F187-32 D08	32	23	15	11	12	11	1,5	15	08	14
F187-40 D06	40	24,5	16	12	12,5	13	1,5	15	06	18
F187-40 D08	40	24,5	16	12	12,5	13	1,5	15	08	21
F187-40 D10	40	24,5	16	12	12,5	13	1,5	17	10	20
F187-50 D06	50	29	20	14	15	14	2	15	06	29
F187-50 D08	50	29	20	14	15	14	2	15	08	31
F187-50 D10	50	29	20	14	15	14	2	17	10	32
F187-60 D08	60	34	24	15,5	18,5	18	2	18	(*) 08	70
F187-60 D10	60	34	24	15,5	18,5	18	2	25	(*) 10	65
F187-60 D12	60	34	24	15,5	18,5	18	2	22	(*) 12	60

ART. F 188

CROSS HANDWHEEL WITH THREADED THROUGH FEMALE INSERT

MATERIAL:

Reinforced polyamide.
Oils and greases resistant.

SURFACE:

Satin.

COLOUR:

Black (RAL 9011).

MAIN INSERT:

Brass right through threaded bush.



SPECIAL REQUESTS:

- It is possible to supply the inserts in different materials, on request and for quantities.
- It is possible to supply colours as shown in the table at page 23, on request and for quantities.

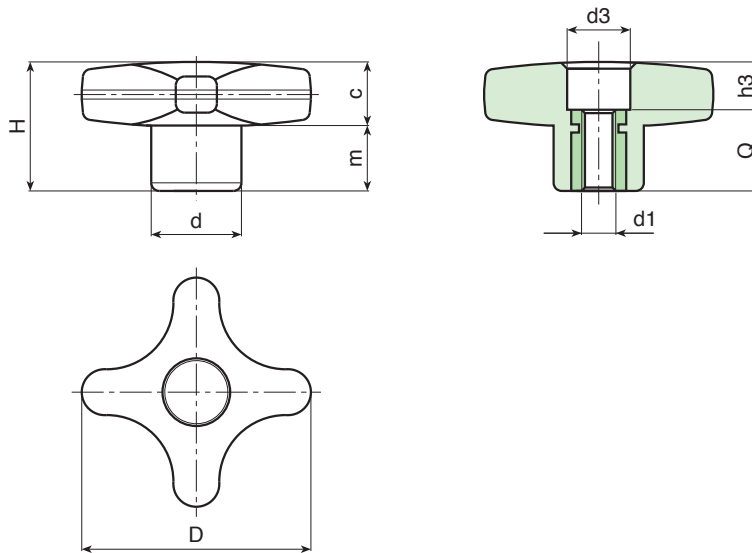

Art.	D	H	d	c	m	d3	h3	Q	d1	Weight (gr)
F188-32 M04	32	23	15	11	11	10	5	18	M4	9
F188-32 M05	32	23	15	11	11	10	5	18	M5	10
F188-32 M06	32	23	15	11	11	10	5	18	M6	10,5
F188-32 M08	32	23	15	11	11	10	5	18	M8	11
F188-40 M06	40	24,5	16	12	12,5	12	6,5	18	M6	13
F188-40 M08	40	24,5	16	12	12,5	12	6,5	18	M8	15
F188-40 M10	40	24,5	16	12	12,5	12	6,5	18	M10	16
F188-50 M06	50	29	20	14	15	14	11	18	M6	23
F188-50 M08	50	29	20	14	15	14	11	18	M8	24
F188-50 M10	50	29	20	14	15	14	11	18	M10	25
F188-50 M12	50	29	20	14	15	14	11	18	M12	26
F188-60 M08	60	34	24	15,5	18,5	16	16	18	M8	34
F188-60 M10	60	34	24	15,5	18,5	16	16	18	M10	38
F188-60 M12	60	34	24	15,5	18,5	16	16	18	M12	40
F188-60 M14	60	34	24	15,5	18,5	16	16	18	M14	45

ART. F 189

CROSS HANDWHEEL WITH THREADED STUD

MATERIAL:

Reinforced polyamide.
Oils and greases resistant.

SURFACE:

Satin.

COLOUR:

Black (RAL 9011).

MAIN INSERT:

Zinc plated steel threaded stud.

SPECIAL REQUESTS:

- It is possible to supply the inserts with different lengths, on request and for quantities.
- It is possible to supply the inserts in different materials, on request and for quantities.
- It is possible to supply colours as shown in the table at page 23, on request and for quantities.

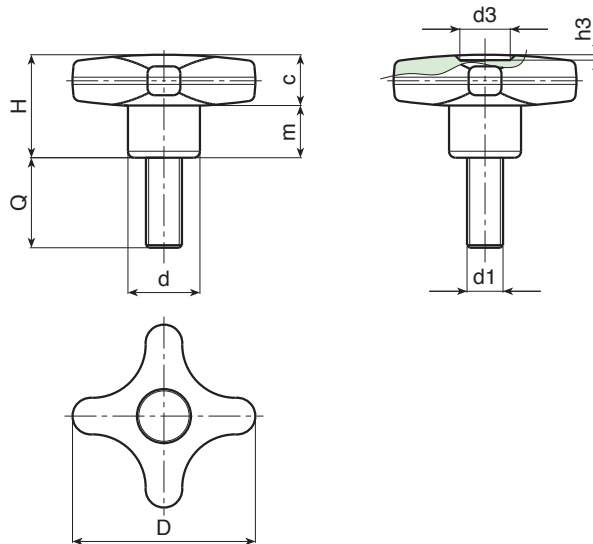

Art.	D	H	d	c	m	d3	h3	d1	Q	Weight (gr)
F189-32 M05	32	23	15	11	11	9	1,5	M5	16-20-30	14-15-16
F189-32 M06	32	23	15	11	11	9	1,5	M6	16-20-30	15-16-17
F189-32 M08	32	23	15	11	11	9	1,5	M8	16-20-30-40	19-21-23-25
F189-32 M10	32	23	15	11	11	9	1,5	M10	20-30-40	24-27-30
F189-40 M06	40	24,5	17	12	12,5	12	1	M6	20-30-40-50	20-21-22-25
F189-40 M08	40	24,5	17	12	12,5	12	1	M8	20-30-40-50	24-29-33-37
F189-40 M10	40	24,5	17	12	12,5	12	1	M10	20-30-40-50	30-35-41-47
F189-50 M08	50	29	20	14	15	14,5	1,5	M8	20-30-40	38-42-46
F189-50 M10	50	29	20	14	15	14,5	1,5	M10	20-30-40-50	49-55-61-65
F189-50 M12	50	29	20	14	15	14,5	1,5	M12	20-30-40-50	51-57-63-70
F189-60 M08	60	34	24	15,5	18,5	18	1,5	M8	20-30-40	47-50-53
F189-60 M10	60	34	24	15,5	18,5	18	1,5	M10	20-30-40-50	64-68-72
F189-60 M12	60	34	24	15,5	18,5	18	1,5	M12	20-30-40-50	78-85-91-99
F189-60 M14	60	34	24	15,5	18,5	18	1,5	M14	30-40-50	82-91-103

ART. F186 CIN

CROSS HANDWHEEL WITH STAINLESS STEEL THREADED FEMALE INSERT

INOX

MATERIAL:

Reinforced polyamide.
Oils and greases resistant.

SURFACE:

Satin.

COLOUR:

Black (RAL 9011).

MAIN INSERT:

Stainless steel blind threaded bush (AISI 303).

SPECIAL REQUESTS:

- It is possible to supply colours as shown in the table at page 23, on request and for quantities.

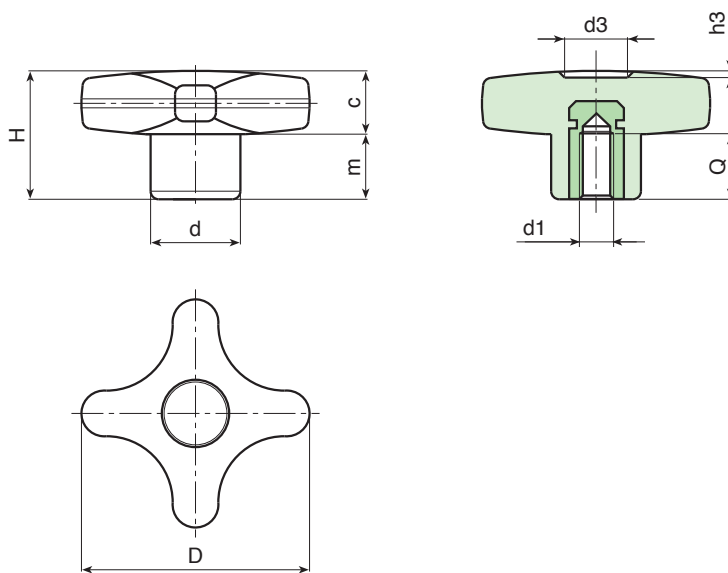

Art.	D	H	d	c	m	d3	h3	Q	d1	Weight (gr)
F186-32 M05 CIN	32	23	15	11	12	11	1,5	14	M5	13
F186-32 M06 CIN	32	23	15	11	12	11	1,5	10	M6	15
F186-32 M08 CIN	32	23	15	11	12	11	1,5	14	M8	15
F186-40 M06 CIN	40	24,5	16	12	12,5	13	1,5	16	M6	17
F186-40 M08 CIN	40	24,5	16	12	12,5	13	1,5	14	M8	18
F186-40 M10 CIN	40	24,5	16	12	12,5	13	1,5	14	M10	19
F186-50 M08 CIN	50	29	20	14	15	14	2	14	M08	27
F186-50 M10 CIN	50	29	20	14	15	14	2	14	M10	29
F186-50 M12 CIN	50	29	20	14	15	14	2	14	M12	30
F186-60 M10 CIN	60	34	24	15,5	18,5	18	2	21	M10	45
F186-60 M12 CIN	60	34	24	15,5	18,5	18	2	18	M12	46

ART. F188 CIN

CROSS HANDWHEEL WITH STAINLESS STEEL THREADED THROUGH FEMALE INSERT

INOX

MATERIAL:

Reinforced polyamide.
Oils and greases resistant.

SURFACE:

Satin.

COLOUR:

Black (RAL 9011).

MAIN INSERT:

Stainless steel right through threaded bush (AISI 303).

SPECIAL REQUESTS:

- It is possible to supply colours as shown in the table at page 23, on request and for quantities.

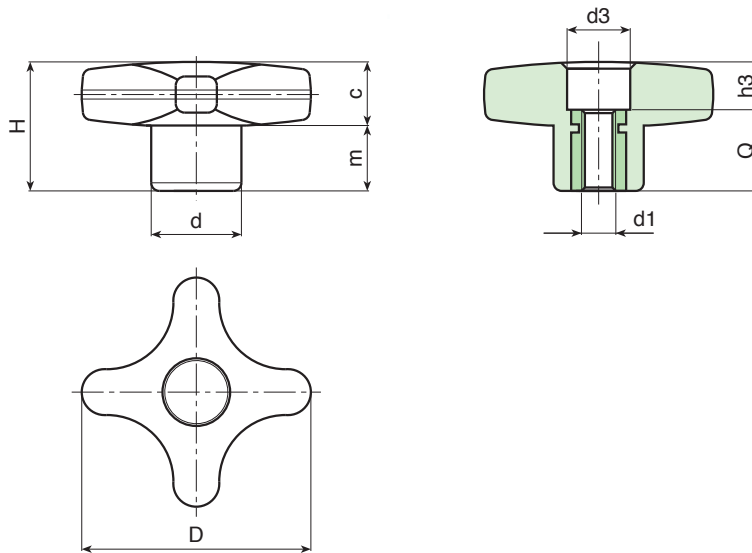

Art.	D	H	d	c	m	d3	h3	Q	d1	Weight (gr)
F188-32 M05 CIN	32	23	15	11	11	10	5	18	M5	10
F188-32 M06 CIN	32	23	15	11	11	10	5	18	M6	10,5
F188-32 M08 CIN	32	23	15	11	11	10	5	18	M8	11
F188-40 M06 CIN	40	24,5	16	12	12,5	12	6,5	18	M6	13
F188-40 M08 CIN	40	24,5	16	12	12,5	12	6,5	18	M8	15
F188-40 M10 CIN	40	24,5	16	12	12,5	12	6,5	18	M10	16
F188-50 M08 CIN	50	29	20	14	15	14	11	18	M8	24
F188-50 M10 CIN	50	29	20	14	15	14	11	18	M10	25
F188-50 M12 CIN	50	29	20	14	15	14	11	18	M12	26
F188-60 M10 CIN	60	34	24	15,5	18,5	16	16	18	M10	38
F188-60 M12 CIN	60	34	24	15,5	18,5	16	16	18	M12	40

ART. F189 CIN

CROSS HANDWHEEL WITH STAINLESS STEEL THREADED STUD

INOX

MATERIAL:

Reinforced polyamide.
Oils and greases resistant.

SURFACE:

Satin.

COLOUR:

Black (RAL 9011).

MAIN INSERT:

Stainless steel threaded stud (AISI 304).

SPECIAL REQUESTS:

- It is possible to supply the inserts with different lengths, on request and for quantities.
- It is possible to supply colours as shown in the table at page 23, on request and for quantities.

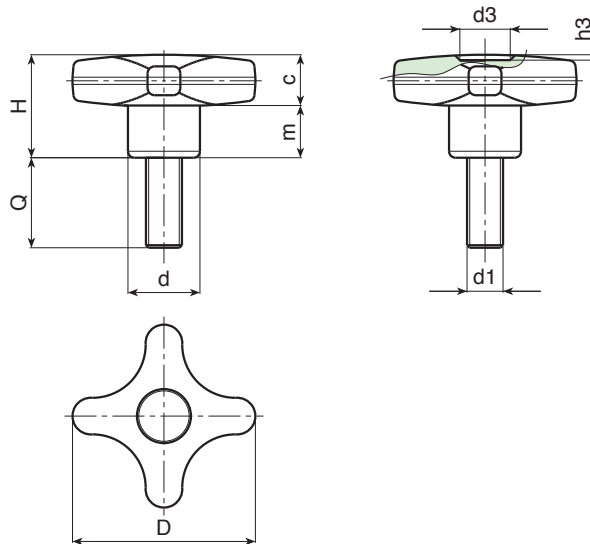

Art.	D	H	d	c	m	d3	h3	d1	Q	Weight (gr)
F189-32 M05 CIN	32	23	15	11	11	9	1,5	M5	20-40	17-19
F189-32 M06 CIN	32	23	15	11	11	9	1,5	M6	20-30	19-22
F189-32 M08 CIN	32	23	15	11	11	9	1,5	M8	20-30-40	24-26-29
F189-40 M06 CIN	40	24,5	17	12	12,5	12	1	M6	20-30-40	20-21-22
F189-40 M08 CIN	40	24,5	17	12	12,5	12	1	M8	20-30-40	24-29-33
F189-40 M10 CIN	40	24,5	17	12	12,5	12	1	M10	20-30-40	30-35-41-47
F189-50 M08 CIN	50	29	20	14	15	14,5	1,5	M8	20-30-40	38-42-46
F189-50 M10 CIN	50	29	20	14	15	14,5	1,5	M10	20-30-40-50	49-55-61-65
F189-50 M12 CIN	50	29	20	14	15	14,5	1,5	M12	20-30-40-50	51-57-63-70
F189-60 M08 CIN	60	34	24	15,5	18,5	18	1,5	M8	20-30-40	47-50-53
F189-60 M10 CIN	60	34	24	15,5	18,5	18	1,5	M10	20-30-40-50	64-68-72-76
F189-60 M12 CIN	60	34	24	15,5	18,5	18	1,5	M12	20-30-40-50	78-85-91-99
F189-60 M14 CIN	60	34	24	15,5	18,5	18	1,5	M14	30-40	100-110

ART. F761-F661

3-LOBE HANDWHEEL WITH THREADED FEMALE INSERT

MATERIAL:

Reinforced polyamide.
Oils and greases resistant.

SURFACE:

Satin.

COLOUR:

Black (RAL 9011).

MAIN INSERT:

Brass blind threaded bush.
(*) Zinc plated steel blind threaded bush.

HUB:

F661 Version - solid.
F761 Version - hollow underneath.



SPECIAL REQUESTS:

- It is possible to supply the inserts in different materials, on request and for quantities.
- It is possible to supply colours as shown in the table at page 23, on request and for quantities.

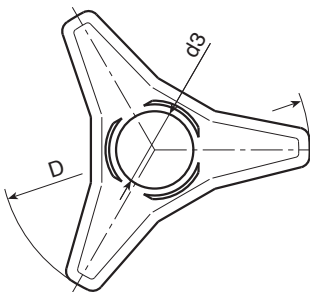
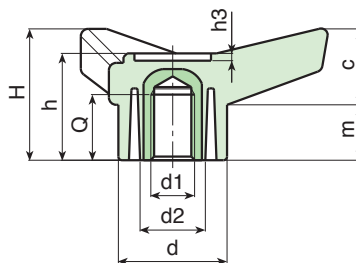

Art.		D	H	h	d	c	m	d2	d3	h3	Q	d1	Weight (gr)
hollow hub	solid hub												
-	F661 -45 M06	45	21	18	16	11	10	-/-	11	1	9	M06	10
-	F661 -45 M08	45	21	18	16	11	10	-/-	11	1	11	M08	14
-	F661 -45 M10	45	21	18	16	11	10	-/-	11	1	10	M10	15
-	F661 -65 M08	65	28	23,5	22	16,5	11,5	-/-	15,5	1,5	11	M08	28
-	F661 -65 M10	65	28	23,5	22	16,5	11,5	-/-	15,5	1,5	11	M10	29
-	F661 -65 M12	65	28	23,5	22	16,5	11,5	-/-	15,5	1,5	13	M12	31
F761	F661 -85 M08	85	37	30,5	30	21	16	18/-	21	2	15	M08	53
F761	F661 -85 M10	85	37	30,5	30	21	16	18/-	21	2	14	M10	55
F761	F661 -85 M12	85	37	30,5	30	21	16	18/-	21	2	19	M12	60
F761	F661 -105 M08	105	46	37,5	35	26	19	20/-	25	2	15	M08	89
F761	F661 -105 M10	105	46	37,5	35	26	19	20/-	25	2	17	M10	90
F761	F661 -105 M12	105	46	37,5	35	26	19	20/-	25	2	17	M12	97
F761	F661 -105 M14	105	46	37,5	35	26	19	20/-	25	2	19	M14	98
F761	F661 -125 M12	125	54	44	42,5	31	23	26/-	28,5	2	18	M12	160
F761	F661 -125 M14	125	54	44	42,5	31	23	26/-	28,5	2	18	M14	165
-	F661 -125 M16	125	54	44	42,5	31	23	-/-	28,5	2	21	(*) M16	177
-	F661 -125 M18	125	54	44	42,5	31	23	-/-	28,5	2	21	(*) M18	182

ART. F662

3-LOBE HANDWHEEL WITH SMOOTH HOLE

MATERIAL:

Reinforced polyamide.
Oils and greases resistant.

SURFACE:

Satin.

COLOUR:

Black (RAL 9011).

MAIN INSERT:

Zinc plated steel blind bored bush with H7 tolerance.

HUB:

Solid hub.



SPECIAL REQUESTS:

- It is possible to supply the inserts with d1 diameter by customer design, on request and for quantities.
- It is possible to supply the inserts in different materials, on request and for quantities.
- It is possible to supply colours as shown in the table at page 23, on request and for quantities.

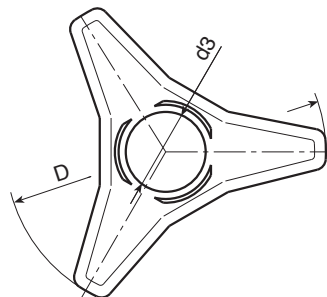
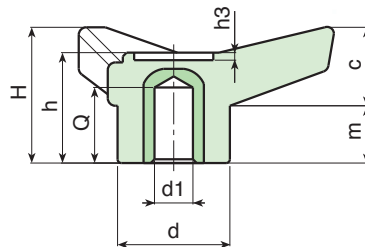

Art.	D	H	h	d	c	m	d3	h3	dm	Q	d1 H7	Weight (gr)
F662-45 D06	45	21	18	16	11	10	11	1	06	8	06	14
F662-65 D05	65	28	23,5	22	16,5	11,5	15,5	1,5	10	13	5 H9	36
F662-65 D10	65	28	23,5	22	16,5	11,5	15,5	1,5	10	12	10	34
F662-85 D05	85	37	30,5	30	21	16	21	2	16	19	5 H9	72
F662-85 D10	85	37	30,5	30	21	16	21	2	16	18	10	67
F662-105 D05	105	46	37,5	35	26	19	25	2	18	25	5 H9	100
F662-105 D12	105	46	37,5	35	26	19	25	2	18	24	12	92
F662-125 D05	125	54	44	42,5	31	23	28	2	22	27	5 H9	193
F662-125 D14	125	54	44	42,5	31	23	28,5	2	22	27	14	181

It's possible to increase the hole, by boring, until **dm**.

ART. F763-F663

3-LOBE HANDWHEEL WITH THREADED THROUGH FEMALE INSERT

MATERIAL:

Reinforced polyamide.
Oils and greases resistant.

SURFACE:

Satin.

COLOUR:

Black (RAL 9011).

MAIN INSERT:

Brass right through threaded bush.
(*) Zinc plated steel blind threaded bush.

HUB:

F661 Version - solid.
F761 Version - hollow underneath.



SPECIAL REQUESTS:

- It is possible to supply the inserts in different materials, on request and for quantities.
- It is possible to supply colours as shown in the table at page 23, on request and for quantities.

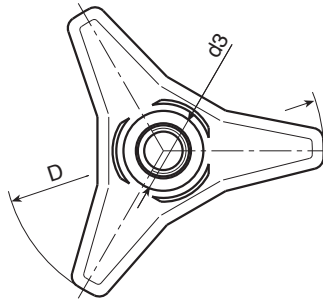
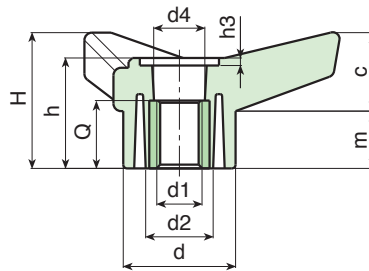

Art.			D	H	h	d	c	m	d2	d3	d4	h3	Q	d1	Weight (gr)
hollow hub	solid hub														
-	F663	-45 M06	45	21	18	16	11	10	-/-	11	10	1	12,5	M06	11
-	F663	-45 M08	45	21	18	16	11	10	-/-	11	10	1	12,5	M08	11
-	F663	-45 M10	45	21	18	16	11	10	-/-	11	10	1	12,5	M10	11
-	F663	-65 M08	65	28	23,5	22	16,5	11,5	-/-	15,5	13,5	1,5	15,5	M08	25
-	F663	-65 M10	65	28	23,5	22	16,5	11,5	-/-	15,5	13,5	1,5	15,5	M10	26
-	F663	-65 M12	65	28	23,5	22	16,5	11,5	-/-	15,5	13,5	1,5	15,5	M12	28
F763	F663	-85 M08	85	37	30,5	30	21	16	18/-	21	13	2	13,5	M08	50
F763	F663	-85 M10	85	37	30,5	30	21	16	18/-	21	13	2	13,5	M10	52
F763	F663	-85 M12	85	37	30,5	30	21	16	18/-	21	13	2	13,5	M12	52
F763	F663	-105 M10	105	46	37,5	35	26	19	20/-	25	23,5	2	23	M10	88
F763	F663	-105 M12	105	46	37,5	35	26	19	20/-	25	23,5	2	23	M12	88
F763	F663	-105 M14	105	46	37,5	35	26	19	20/-	25	23,5	2	21	M14	91
-	F663	-105 M16	105	46	37,5	35	26	19	-/-	25	23,5	2	21	(*) M16	108
F763	F663	-125 M12	125	54	44	42,5	31	23	26/-	28,5	26	2	31	M12	152
F763	F663	-125 M14	125	54	44	42,5	31	23	26/-	28,5	26	2	31	M14	160
-	F663	-125 M16	125	54	44	42,5	31	23	-/-	28,5	26	2	31	(*) M16	180
-	F663	-125 M18	125	54	44	42,5	31	23	-/-	28,5	26	2	31	(*) M18	186

ART. F764-F664

3-LOBE HANDWHEEL WITH THREADED STUD

MATERIAL:

Reinforced polyamide.
Oils and greases resistant.

SURFACE:

Satin.

COLOUR:

Black (RAL 9011).

MAIN INSERT:

Zinc plated steel threaded stud.

HUB:

F661 Version - solid.
F761 Version - hollow underneath.



SPECIAL REQUESTS:

- It is possible to supply the inserts with different lengths, on request and for quantities.
- It is possible to supply the inserts in different materials, on request and for quantities.
- It is possible to supply colours as shown in the table at page 23, on request and for quantities.

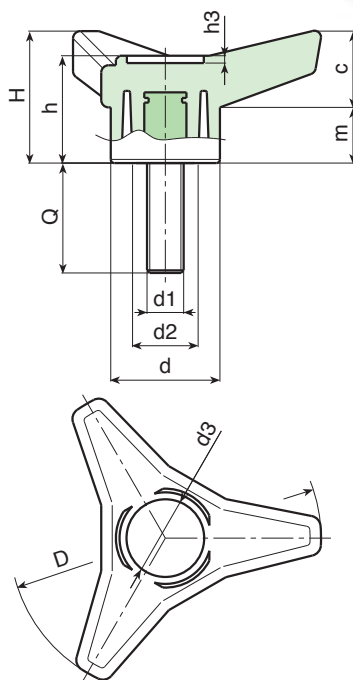

Art.		D	H	h	d	c	m	d2	d3	h3	d1	Q	Weight (gr)
hollow hub	solid hub												
-	F664 -45 M06	45	21	18	16	11	10	-/-	11	1	M06	20-30	14-17
-	F664 -45 M08	45	21	18	16	11	10	-/-	11	1	M08	20-30	19-22
-	F664 -45 M10	45	21	18	16	11	10	-/-	11	1	M10	30	23
-	F664 -65 M08	65	28	23,5	22	16,5	11,5	-/-	15,5	1,5	M08	20-30	36-39
-	F664 -65 M10	65	28	23,5	22	16,5	11,5	-/-	15,5	1,5	M10	20-30	43-47
-	F664 -65 M12	65	28	23,5	22	16,5	11,5	-/-	15,5	1,5	M12	40	67
F764	F664 -85 M08	85	37	30,5	30	21	16	18/-	21	2	M08	20-30-40	61-65-69
F764	F664 -85 M10	85	37	30,5	30	21	16	18/-	21	2	M10	20-30-40	66-74-80
F764	F664 -85 M12	85	37	30,5	30	21	16	18/-	21	2	M12	20-40	83-94
F764	F664 -105 M10	105	46	37,5	35	26	19	20/-	25	2	M10	20-30-40	113-116-122
F764	F664 -105 M12	105	46	37,5	35	26	19	20/-	25	2	M12	30-50	121-136
F764	F664 -105 M14	105	46	37,5	35	26	19	20/-	25	2	M14	30	134
F764	F664 -125 M12	125	54	44	42,5	31	23	26/-	28,5	2	M12	30-50	200-214
F764	F664 -125 M14	125	54	44	42,5	31	23	26/-	28,5	2	M14	30	219
-	F664 -125 M16	125	54	44	42,5	31	23	-/-	28,5	2	M16	30	232
-	F664 -125 M18	125	54	44	42,5	31	23	-/-	28,5	2	M18	30	256

F – SOLID LOCKING HANDWHEELS

































**F – SOLID LOCKING
HANDWHEELS**

© ROLLMEX - Reproduction prohibited

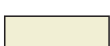

COLOUR CHART

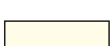
R A L			
COLOUR		RAL	CODE
Black		9011	01
Orange		2004	02
Orange		2011	03
White		9010	04
Blue		5002	05
Blue		5005	06
Blue		5015	07
Blue		5018	19
Blue		5019	21
Blue		5010	22
Yellow		1007	09
Yellow		1021	10
Grey		7024	12
Grey		7035	13
Red		3000	16
Green		6024	17

O T H E R C O L O U R S			
COLOUR		REF.	CODE
White		-	52
Blue		-	53
Blue		pant. 645 U	54
Blue		pant. 300	55
Grey		-	57
Grey		-	59
Grey		NCS 7500	60
Red		-	64
Red		-	65
Natural		-	66
Green		-	70
Brown		-	71
Cream		-	72
Violet		-	73



WWW.ROLLMEX.FI

ROLLMEX Oy

Takojankatu 4 - 33540 TAMPERE
Push. 010-6661122 - Fax 03-3640072
tamper@rollmex.fi

Karjalankatu 21 - 15140 LAHTI
Push. 010-6661121 - Fax 03-7511026
lahti@rollmex.fi

AUTHORISED RESELLER