

**F – FAMILY  
FIXED AND  
INDEXED  
CRANK HANDLES**



 **ROLLMEX**

# ART. E215

## CRANK HANDLE WITH THREADED INSERT AND REVOLVING HANDLE

**MATERIAL:**

Reinforced polyamide.  
Oils and greases resistant.

**SURFACE:**

Satin.

**COLOUR:**

Black (RAL 9011).

**MAIN INSERT:**

Brass blind threaded bush.  
(\* ) Zinc plated steel blind threaded bush.

**SIDE INSERT:**

Brass right through threaded bush.

**SIDE HANDLE:**

Revolving handle Art. M144 (see chapter M on page 6).



**SPECIAL REQUESTS:**

- It is possible to supply the inserts in different materials, on request and for quantities.
- It is possible to supply arm and handle with colours as shown in the table at page 15, on request and for quantities.

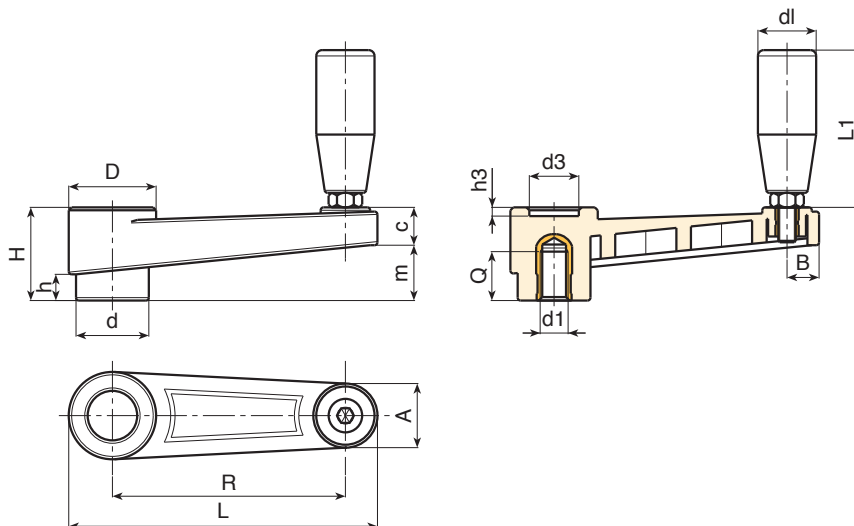

| Art.         | L   | R   | H  | D  | d    | m  | c    | A    | B    | h    | d3   | h3  | d1       | Q  | d1 | L1 | Weight (gr) |
|--------------|-----|-----|----|----|------|----|------|------|------|------|------|-----|----------|----|----|----|-------------|
| E215-65 M08  | 88  | 65  | 30 | 26 | 22   | 17 | 13   | 18   | 9,5  | 8    | 15   | 3   | M08      | 15 | 20 | 56 | 67          |
| E215-65 M10  | 88  | 65  | 30 | 26 | 22   | 17 | 13   | 18   | 9,5  | 8    | 15   | 3   | M10      | 15 | 20 | 56 | 70          |
| E215-65 M12  | 88  | 65  | 30 | 26 | 22   | 17 | 13   | 18   | 9,5  | 8    | 15   | 3   | M12      | 18 | 20 | 56 | 73          |
| E215-80 M08  | 106 | 80  | 33 | 30 | 26   | 20 | 13   | 21,5 | 11   | 9    | 17   | 3   | M08      | 18 | 20 | 56 | 83          |
| E215-80 M10  | 106 | 80  | 33 | 30 | 26   | 20 | 13   | 21,5 | 11   | 9    | 17   | 3   | M10      | 18 | 20 | 56 | 87          |
| E215-80 M12  | 106 | 80  | 33 | 30 | 26   | 20 | 13   | 21,5 | 11   | 9    | 17   | 3   | M12      | 18 | 20 | 56 | 90          |
| E215-110 M10 | 138 | 110 | 39 | 33 | 28,5 | 22 | 14   | 22   | 12   | 11   | 21   | 3,5 | M10      | 14 | 21 | 65 | 135         |
| E215-110 M12 | 138 | 110 | 39 | 33 | 28,5 | 22 | 14   | 22   | 12   | 11   | 21   | 3,5 | M12      | 18 | 21 | 65 | 137         |
| E215-110 M14 | 138 | 110 | 39 | 33 | 28,5 | 22 | 14   | 22   | 12   | 11   | 21   | 3,5 | M14      | 18 | 21 | 65 | 140         |
| E215-140 M12 | 173 | 140 | 49 | 43 | 35   | 34 | 16   | 25,5 | 13,5 | 15   | 27   | 3   | M12      | 19 | 23 | 76 | 238         |
| E215-140 M14 | 173 | 140 | 49 | 43 | 35   | 34 | 16   | 25,5 | 13,5 | 15   | 27   | 3   | M14      | 18 | 23 | 76 | 223         |
| E215-140 M16 | 173 | 140 | 49 | 43 | 35   | 34 | 16   | 25,5 | 13,5 | 15   | 27   | 3   | (* ) M16 | 18 | 23 | 76 | 251         |
| E215-185 M12 | 219 | 180 | 54 | 46 | 39   | 40 | 16,5 | 26,5 | 14   | 16,5 | 27,5 | 4   | M12      | 17 | 25 | 86 | 312         |
| E215-185 M14 | 219 | 180 | 54 | 46 | 39   | 40 | 16,5 | 26,5 | 14   | 16,5 | 27,5 | 4   | M14      | 19 | 25 | 86 | 320         |
| E215-185 M16 | 219 | 180 | 54 | 46 | 39   | 40 | 16,5 | 26,5 | 14   | 16,5 | 27,5 | 4   | (* ) M16 | 18 | 25 | 86 | 331         |

# ART. E220

## CRANK HANDLE WITH THREADED INSERT AND REVOLVING HANDLE M145



**MATERIAL:**  
Reinforced polyamide.  
Oils and greases resistant.

**SURFACE:**  
Satin.

**COLOUR:**  
Black (RAL 9011).

**MAIN INSERT:**  
Brass blind threaded bush.  
(\*) Zinc plated steel blind threaded bush.

**SIDE INSERT:**  
Brass right through threaded bush.

**SIDE HANDLE:**  
Revolving handle Art. M145  
(see chapter M on page 8).

**SPECIAL REQUESTS:**

- It is possible to supply the inserts in different materials, on request and for quantities.
- It is possible to supply arm and handle with colours as shown in the table at page 15, on request and for quantities.

| Art.         | L   | R   | H  | D  | d    | m  | c    | A    | B    | h    | d3   | h3  | d1      | Q  | dl | L1 | Weight (gr) |
|--------------|-----|-----|----|----|------|----|------|------|------|------|------|-----|---------|----|----|----|-------------|
| E220-65 M08  | 88  | 65  | 30 | 26 | 22   | 17 | 13   | 18   | 9,5  | 8    | 15   | 3   | M08     | 15 | 20 | 56 | 69          |
| E220-65 M10  | 88  | 65  | 30 | 26 | 22   | 17 | 13   | 18   | 9,5  | 8    | 15   | 3   | M10     | 15 | 20 | 56 | 72          |
| E220-65 M12  | 88  | 65  | 30 | 26 | 22   | 17 | 13   | 18   | 9,5  | 8    | 15   | 3   | M12     | 18 | 20 | 56 | 75          |
| E220-80 M08  | 106 | 80  | 33 | 30 | 26   | 19 | 13   | 21,5 | 11   | 9    | 17   | 3   | M08     | 18 | 20 | 56 | 85          |
| E220-80 M10  | 106 | 80  | 33 | 30 | 26   | 19 | 13   | 21,5 | 11   | 9    | 17   | 3   | M10     | 18 | 20 | 56 | 89          |
| E220-80 M12  | 106 | 80  | 33 | 30 | 26   | 19 | 13   | 21,5 | 11   | 9    | 17   | 3   | M12     | 18 | 20 | 56 | 92          |
| E220-110 M10 | 138 | 110 | 39 | 33 | 28,5 | 22 | 14   | 22   | 12   | 11   | 21   | 3,5 | M10     | 14 | 23 | 66 | 149         |
| E220-110 M12 | 138 | 110 | 39 | 33 | 28,5 | 22 | 14   | 22   | 12   | 11   | 21   | 3,5 | M12     | 18 | 23 | 66 | 151         |
| E220-110 M14 | 138 | 110 | 39 | 33 | 28,5 | 22 | 14   | 22   | 12   | 11   | 21   | 3,5 | M14     | 18 | 23 | 66 | 154         |
| E220-140 M12 | 173 | 140 | 49 | 43 | 35   | 34 | 16   | 25,5 | 13,5 | 15   | 27   | 3   | M12     | 19 | 25 | 77 | 228         |
| E220-140 M14 | 173 | 140 | 49 | 43 | 35   | 34 | 16   | 25,5 | 13,5 | 15   | 27   | 3   | M14     | 18 | 25 | 77 | 213         |
| E220-140 M16 | 173 | 140 | 49 | 43 | 35   | 34 | 16   | 25,5 | 13,5 | 15   | 27   | 3   | (*) M16 | 18 | 25 | 77 | 241         |
| E220-185 M12 | 219 | 180 | 54 | 46 | 39   | 40 | 16,5 | 26,5 | 14   | 16,5 | 27,5 | 4   | M12     | 17 | 25 | 87 | 304         |
| E220-185 M14 | 219 | 180 | 54 | 46 | 39   | 40 | 16,5 | 26,5 | 14   | 16,5 | 27,5 | 4   | M14     | 19 | 25 | 87 | 310         |
| E220-185 M16 | 219 | 180 | 54 | 46 | 39   | 40 | 16,5 | 26,5 | 14   | 16,5 | 27,5 | 4   | (*) M16 | 18 | 25 | 87 | 321         |

# ART. E219

## CRANK HANDLE WITH THREADED INSERT AND REVOLVING HANDLE M129



**MATERIAL:**  
Reinforced polyamide.  
Oils and greases resistant.

**SURFACE:**  
Satin.

**COLOUR:**  
Black (RAL 9011).

**MAIN INSERT:**  
Brass blind threaded bush.  
(\*) Zinc plated steel blind threaded bush.

**SIDE INSERT:**  
Brass right through threaded bush.

**SIDE HANDLE:**  
Revolving handle Art. M129  
(see chapter M on page 9).

**SPECIAL REQUESTS:**

- It is possible to supply the inserts in different materials, on request and for quantities.
- It is possible to supply arm and handle with colours as shown in the table at page 15, on request and for quantities.

| Art.         | L   | R   | H  | D  | d    | m  | c    | A    | B    | h    | d3   | h3  | d1      | Q  | dl | L1 | Weight (gr) |
|--------------|-----|-----|----|----|------|----|------|------|------|------|------|-----|---------|----|----|----|-------------|
| E219-65 M08  | 88  | 65  | 30 | 26 | 22   | 17 | 13   | 18   | 9,5  | 8    | 15   | 3   | M08     | 15 | 20 | 52 | 79          |
| E219-65 M10  | 88  | 65  | 30 | 26 | 22   | 17 | 13   | 18   | 9,5  | 8    | 15   | 3   | M10     | 15 | 20 | 52 | 82          |
| E219-65 M12  | 88  | 65  | 30 | 26 | 22   | 17 | 13   | 18   | 9,5  | 8    | 15   | 3   | M12     | 18 | 20 | 52 | 85          |
| E219-80 M08  | 106 | 80  | 33 | 30 | 26   | 19 | 13   | 21,5 | 11   | 9    | 17   | 3   | M08     | 18 | 20 | 52 | 95          |
| E219-80 M10  | 106 | 80  | 33 | 30 | 26   | 19 | 13   | 21,5 | 11   | 9    | 17   | 3   | M10     | 18 | 20 | 52 | 99          |
| E219-80 M12  | 106 | 80  | 33 | 30 | 26   | 19 | 13   | 21,5 | 11   | 9    | 17   | 3   | M12     | 18 | 20 | 52 | 102         |
| E219-110 M10 | 138 | 110 | 39 | 33 | 28,5 | 22 | 14   | 22   | 12   | 11   | 21   | 3,5 | M10     | 14 | 23 | 62 | 150         |
| E219-110 M12 | 138 | 110 | 39 | 33 | 28,5 | 22 | 14   | 22   | 12   | 11   | 21   | 3,5 | M12     | 18 | 23 | 62 | 160         |
| E219-110 M14 | 138 | 110 | 39 | 33 | 28,5 | 22 | 14   | 22   | 12   | 11   | 21   | 3,5 | M14     | 18 | 23 | 62 | 165         |
| E219-140 M12 | 173 | 140 | 49 | 43 | 35   | 34 | 16   | 25,5 | 13,5 | 15   | 27   | 3   | M12     | 19 | 25 | 72 | 262         |
| E219-140 M14 | 173 | 140 | 49 | 43 | 35   | 34 | 16   | 25,5 | 13,5 | 15   | 27   | 3   | M14     | 18 | 25 | 72 | 249         |
| E219-140 M16 | 173 | 140 | 49 | 43 | 35   | 34 | 16   | 25,5 | 13,5 | 15   | 27   | 3   | (*) M16 | 18 | 25 | 72 | 275         |
| E219-185 M12 | 219 | 180 | 54 | 46 | 39   | 40 | 16,5 | 26,5 | 14   | 16,5 | 27,5 | 4   | M12     | 17 | 25 | 82 | 312         |
| E219-185 M14 | 219 | 180 | 54 | 46 | 39   | 40 | 16,5 | 26,5 | 14   | 16,5 | 27,5 | 4   | M14     | 19 | 25 | 82 | 320         |
| E219-185 M16 | 219 | 180 | 54 | 46 | 39   | 40 | 16,5 | 26,5 | 14   | 16,5 | 27,5 | 4   | (*) M16 | 18 | 25 | 82 | 331         |

# ART. E218

## CRANK HANDLE WITH THREADED INSERT AND REVOLVING AND FOLDING HANDLE

**MATERIAL:**

Reinforced polyamide.  
Oils and greases resistant.

**SURFACE:**

Satin.

**COLOUR:**

Black (RAL 9011).

**MAIN INSERT:**

Brass blind threaded bush.  
(\* ) Zinc plated steel blind threaded bush.

**SIDE INSERT:**

Brass right through threaded bush.

**SIDE HANDLE:**

Revolving handle and folding Art. M136  
(see chapter M on page 10).



**SPECIAL REQUESTS:**

- It is possible to supply the inserts in different materials, on request and for quantities.
- It is possible to supply arm and handle with colours as shown in the table at page 15, on request and for quantities.

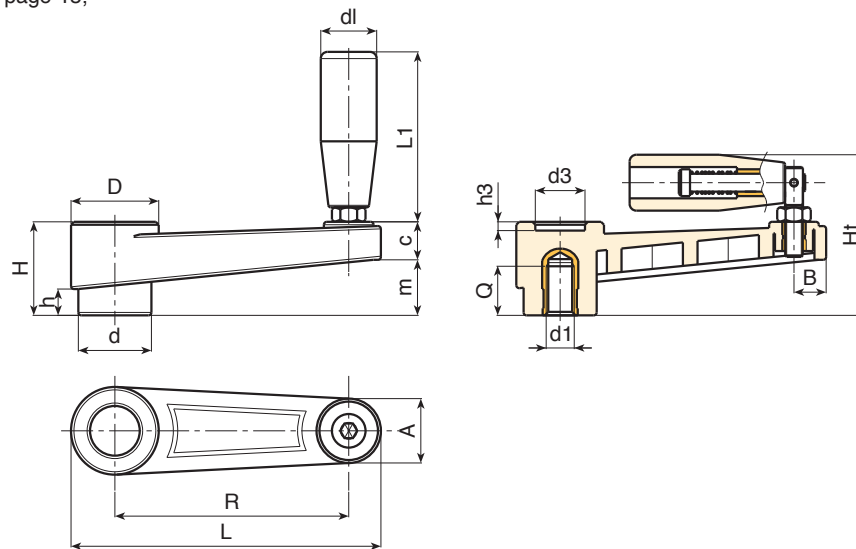

| Art.         | L   | R   | H  | Ht   | D  | d    | m  | c    | A    | B    | h    | d3   | h3  | d1      | Q  | dl | L1 | Weight (gr) |
|--------------|-----|-----|----|------|----|------|----|------|------|------|------|------|-----|---------|----|----|----|-------------|
| E218-65 M08  | 88  | 65  | 30 | 54   | 26 | 22   | 17 | 13   | 18   | 9,5  | 8    | 15   | 3   | M08     | 15 | 20 | 54 | 78          |
| E218-65 M10  | 88  | 65  | 30 | 54   | 26 | 22   | 17 | 13   | 18   | 9,5  | 8    | 15   | 3   | M10     | 15 | 20 | 54 | 78          |
| E218-65 M12  | 88  | 65  | 30 | 54   | 26 | 22   | 17 | 13   | 18   | 9,5  | 8    | 15   | 3   | M12     | 18 | 20 | 54 | 83          |
| E218-80 M08  | 106 | 80  | 33 | 57   | 30 | 26   | 19 | 13   | 21,5 | 11   | 9    | 17   | 3   | M08     | 18 | 20 | 54 | 94          |
| E218-80 M10  | 106 | 80  | 33 | 57   | 30 | 26   | 19 | 13   | 21,5 | 11   | 9    | 17   | 3   | M10     | 18 | 20 | 54 | 95          |
| E218-80 M12  | 106 | 80  | 33 | 57   | 30 | 26   | 19 | 13   | 21,5 | 11   | 9    | 17   | 3   | M12     | 18 | 20 | 54 | 100         |
| E218-110 M10 | 138 | 110 | 39 | 67,5 | 33 | 28,5 | 22 | 14   | 22   | 12   | 11   | 21   | 3,5 | M10     | 16 | 25 | 75 | 156         |
| E218-110 M12 | 138 | 110 | 39 | 67,5 | 33 | 28,5 | 22 | 14   | 22   | 12   | 11   | 21   | 3,5 | M12     | 18 | 25 | 75 | 156         |
| E218-110 M14 | 138 | 110 | 39 | 67,5 | 33 | 28,5 | 22 | 14   | 22   | 12   | 11   | 21   | 3,5 | M14     | 18 | 25 | 75 | 156         |
| E218-140 M12 | 173 | 140 | 49 | 82   | 43 | 35   | 34 | 16   | 25,5 | 13,5 | 15   | 27   | 3   | M12     | 19 | 26 | 89 | 274         |
| E218-140 M14 | 173 | 140 | 49 | 82   | 43 | 35   | 34 | 16   | 25,5 | 13,5 | 15   | 27   | 3   | M14     | 18 | 26 | 89 | 283         |
| E218-140 M16 | 173 | 140 | 49 | 82   | 43 | 35   | 34 | 16   | 25,5 | 13,5 | 15   | 27   | 3   | M16 (*) | 18 | 26 | 89 | 290         |
| E218-185 M12 | 219 | 180 | 54 | 88   | 46 | 39   | 40 | 16,5 | 26,5 | 14   | 16,5 | 27,5 | 4   | M12     | 17 | 26 | 97 | 340         |
| E218-185 M14 | 219 | 180 | 54 | 88   | 46 | 39   | 40 | 16,5 | 26,5 | 14   | 16,5 | 27,5 | 4   | M14     | 19 | 26 | 97 | 345         |
| E218-185 M16 | 219 | 180 | 54 | 88   | 46 | 39   | 40 | 16,5 | 26,5 | 14   | 16,5 | 27,5 | 4   | M16 (*) | 18 | 26 | 97 | 360         |

# ART. E216

## CRANK HANDLE WITH SMOOTH INSERT AND REVOLVING HANDLE

**MATERIAL:**

Reinforced polyamide.  
Oils and greases resistant.

**SURFACE:**

Satin.

**COLOUR:**

Black (RAL 9011).

**MAIN INSERT:**

Zinc plated steel blind bored bush with H7 tolerance.

**SIDE INSERT:**

Brass right through threaded bush.

**SIDE HANDLE:**

Revolving handle Art. M144 (see chapter M on page 6).



**SPECIAL REQUESTS:**

- It is possible to supply the inserts with d1 diameter by customer design, on request and for quantities.
- It is possible to supply the inserts with different treatment-finishes, on request and for quantities.
- It is possible to supply the inserts in different materials, on request and for quantities.
- It is possible to supply arm and handle with colours as shown in the table at page 15, on request and for quantities.

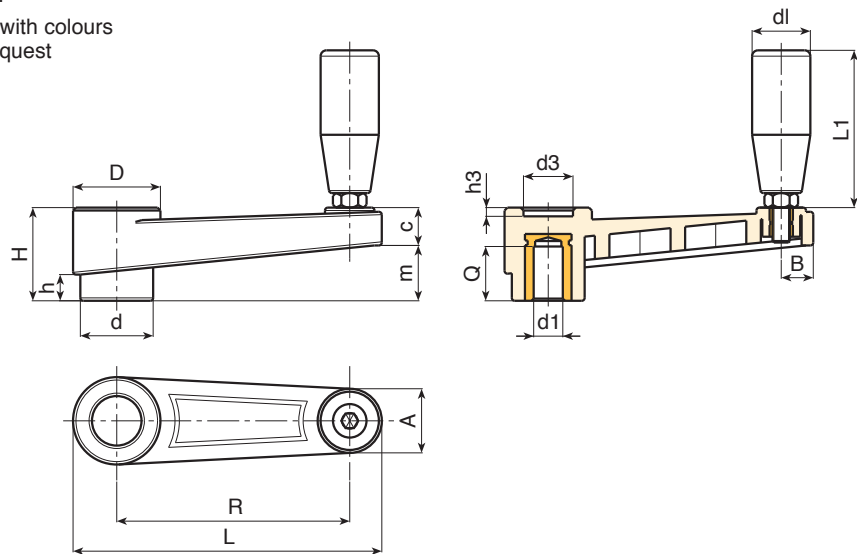

| Art.         | L   | R   | H  | D  | d    | m  | c    | A    | B    | h    | d3   | h3  | dm | d1 H7  | Q  | dI | L1 | Weight (gr) |
|--------------|-----|-----|----|----|------|----|------|------|------|------|------|-----|----|--------|----|----|----|-------------|
| E216-65 D05  | 88  | 65  | 30 | 26 | 22   | 17 | 13   | 18   | 9,5  | 8    | 15   | 3   | 12 | D05 H9 | 20 | 20 | 56 | 96          |
| E216-65 D10  | 88  | 65  | 30 | 26 | 22   | 17 | 13   | 18   | 9,5  | 8    | 15   | 3   | 12 | D10    | 20 | 20 | 56 | 92          |
| E216-80 D05  | 106 | 80  | 33 | 30 | 26   | 19 | 13   | 21,5 | 11   | 9    | 17   | 3   | 14 | D05 H9 | 20 | 20 | 56 | 110         |
| E216-80 D10  | 106 | 80  | 33 | 30 | 26   | 19 | 13   | 21,5 | 11   | 9    | 17   | 3   | 14 | D10    | 20 | 20 | 56 | 105         |
| E216-110 D05 | 138 | 110 | 39 | 33 | 28,5 | 22 | 14   | 22   | 12   | 11   | 21   | 3,5 | 14 | D05 H9 | 22 | 21 | 66 | 160         |
| E216-110 D12 | 138 | 110 | 39 | 33 | 28,5 | 22 | 14   | 22   | 12   | 11   | 21   | 3,5 | 14 | D12    | 22 | 21 | 66 | 152         |
| E216-140 D05 | 173 | 140 | 49 | 43 | 35   | 34 | 16   | 25,5 | 13,5 | 15   | 27   | 3   | 20 | D05 H9 | 22 | 23 | 76 | 250         |
| E216-140 D14 | 173 | 140 | 49 | 43 | 35   | 34 | 16   | 25,5 | 13,5 | 15   | 27   | 3   | 20 | D14    | 22 | 23 | 76 | 242         |
| E216-185 D05 | 219 | 180 | 54 | 46 | 39   | 40 | 16,5 | 26,5 | 14   | 16,5 | 27,5 | 4   | 24 | D05 H9 | 26 | 25 | 86 | 430         |
| E216-185 D16 | 219 | 180 | 54 | 46 | 39   | 40 | 16,5 | 26,5 | 14   | 16,5 | 27,5 | 4   | 24 | D16    | 26 | 25 | 86 | 385         |

It's possible to increase the hole, by boring, until **dm**.

## ART. E221

### CRANK HANDLE WITH SMOOTH INSERT AND REVOLVING HANDLE M145



**MATERIAL:**

Reinforced polyamide.  
Oils and greases resistant.

**SURFACE:**

Satin.

**COLOUR:**

Black (RAL 9011).

**MAIN INSERT:**

Zinc plated steel blind bored bush with H7 tolerance.

**SIDE INSERT:**

Brass right through threaded bush.

**SIDE HANDLE:**

Revolving handle Art. M145  
(see chapter M on page 8).

**SPECIAL REQUESTS:**

- It is possible to supply the inserts with d1 diameter by customer design, on request and for quantities.
- It is possible to supply the inserts with different treatment-finishes, on request and for quantities.
- It is possible to supply the inserts in different materials, on request and for quantities.
- It is possible to supply arm and handle with colours as shown in the table at page 15, on request and for quantities.

| Art.         | L   | R   | H  | D  | d    | m  | c    | A    | B    | h    | d3   | h3  | dm | d1     | Q  | dl | L1 | Weight (gr) |
|--------------|-----|-----|----|----|------|----|------|------|------|------|------|-----|----|--------|----|----|----|-------------|
| E221-65 D05  | 88  | 65  | 30 | 26 | 22   | 17 | 13   | 18   | 9,5  | 8    | 15   | 3   | 12 | D05 H9 | 20 | 20 | 56 | 101         |
| E221-65 D10  | 88  | 65  | 30 | 26 | 22   | 17 | 13   | 18   | 9,5  | 8    | 15   | 3   | 12 | D10    | 20 | 20 | 56 | 107         |
| E221-80 D05  | 106 | 80  | 33 | 30 | 26   | 19 | 13   | 21,5 | 11   | 9    | 17   | 3   | 14 | D05 H9 | 20 | 20 | 56 | 125         |
| E221-80 D10  | 106 | 80  | 33 | 30 | 26   | 19 | 13   | 21,5 | 11   | 9    | 17   | 3   | 14 | D10    | 20 | 20 | 56 | 130         |
| E221-110 D05 | 138 | 110 | 39 | 33 | 28,5 | 22 | 14   | 22   | 12   | 11   | 21   | 3,5 | 14 | D05 H9 | 22 | 23 | 66 | 175         |
| E221-110 D12 | 138 | 110 | 39 | 33 | 28,5 | 22 | 14   | 22   | 12   | 11   | 21   | 3,5 | 14 | D12    | 22 | 23 | 66 | 167         |
| E221-140 D05 | 173 | 140 | 49 | 43 | 35   | 34 | 16   | 25,5 | 13,5 | 15   | 27   | 3   | 20 | D05 H9 | 22 | 25 | 77 | 265         |
| E221-140 D14 | 173 | 140 | 49 | 43 | 35   | 34 | 16   | 25,5 | 13,5 | 15   | 27   | 3   | 20 | D14    | 22 | 25 | 77 | 257         |
| E221-185 D05 | 219 | 180 | 54 | 46 | 39   | 40 | 16,5 | 26,5 | 14   | 16,5 | 27,5 | 4   | 24 | D05 H9 | 26 | 25 | 87 | 445         |
| E221-185 D16 | 219 | 180 | 54 | 46 | 39   | 40 | 16,5 | 26,5 | 14   | 16,5 | 27,5 | 4   | 24 | D16    | 26 | 25 | 87 | 390         |

It's possible to increase the hole, by boring, until **dm**.

## ART. E222

### CRANK HANDLE WITH SMOOTH INSERT AND REVOLVING HANDLE M129



**MATERIAL:**

Reinforced polyamide.  
Oils and greases resistant.

**SURFACE:**

Satin.

**COLOUR:**

Black (RAL 9011).

**MAIN INSERT:**

Zinc plated steel blind bored bush with H7 tolerance.

**SIDE INSERT:**

Brass right through threaded bush.

**SIDE HANDLE:**

Revolving handle Art. M129  
(see chapter M on page 9).

**SPECIAL REQUESTS:**

- It is possible to supply the inserts with d1 diameter by customer design, on request and for quantities.
- It is possible to supply the inserts with different treatment-finishes, on request and for quantities.
- It is possible to supply the inserts in different materials, on request and for quantities.
- It is possible to supply arm and handle with colours as shown in the table at page 15, on request and for quantities.

| Art.         | L   | R   | H  | D  | d    | m  | c    | A    | B    | h    | d3   | h3  | dm | d1     | Q  | dl | L1 | Weight (gr) |
|--------------|-----|-----|----|----|------|----|------|------|------|------|------|-----|----|--------|----|----|----|-------------|
| E222-65 D05  | 88  | 65  | 30 | 26 | 22   | 17 | 13   | 18   | 9,5  | 8    | 15   | 3   | 12 | D05 H9 | 20 | 20 | 52 | 111         |
| E222-65 D10  | 88  | 65  | 30 | 26 | 22   | 17 | 13   | 18   | 9,5  | 8    | 15   | 3   | 12 | D10    | 20 | 20 | 52 | 117         |
| E222-80 D05  | 106 | 80  | 33 | 30 | 26   | 19 | 13   | 21,5 | 11   | 9    | 17   | 3   | 14 | D05 H9 | 20 | 20 | 52 | 135         |
| E222-80 D10  | 106 | 80  | 33 | 30 | 26   | 19 | 13   | 21,5 | 11   | 9    | 17   | 3   | 14 | D10    | 20 | 20 | 52 | 140         |
| E222-110 D05 | 138 | 110 | 39 | 33 | 28,5 | 22 | 14   | 22   | 12   | 11   | 21   | 3,5 | 14 | D05 H9 | 22 | 23 | 62 | 185         |
| E222-110 D12 | 138 | 110 | 39 | 33 | 28,5 | 22 | 14   | 22   | 12   | 11   | 21   | 3,5 | 14 | D12    | 22 | 23 | 62 | 177         |
| E222-140 D05 | 173 | 140 | 49 | 43 | 35   | 34 | 16   | 25,5 | 13,5 | 15   | 27   | 3   | 20 | D05 H9 | 22 | 25 | 72 | 275         |
| E222-140 D14 | 173 | 140 | 49 | 43 | 35   | 34 | 16   | 25,5 | 13,5 | 15   | 27   | 3   | 20 | D14    | 22 | 25 | 72 | 267         |
| E222-185 D05 | 219 | 180 | 54 | 46 | 39   | 40 | 16,5 | 26,5 | 14   | 16,5 | 27,5 | 4   | 24 | D05 H9 | 26 | 25 | 82 | 455         |
| E222-185 D16 | 219 | 180 | 54 | 46 | 39   | 40 | 16,5 | 26,5 | 14   | 16,5 | 27,5 | 4   | 24 | D16    | 26 | 25 | 82 | 400         |

It's possible to increase the hole, by boring, until **dm**.

E – FIXED AND INDEXED CRANK HANDLES



# ART. E217

## CRANK HANDLE WITH SMOOTH INSERT AND REVOLVING AND FOLDING HANDLE

**MATERIAL:**

Reinforced polyamide.  
Oils and greases resistant.

**SURFACE:**

Satin.

**COLOUR:**

Black (RAL 9011).

**MAIN INSERT:**

Zinc plated steel blind bored bush with H7 tolerance.

**SIDE INSERT:**

Brass right through threaded bush.

**SIDE HANDLE:**

Revolving handle and folding Art. M136  
(see chapter M on page 10).



**SPECIAL REQUESTS:**

- It is possible to supply the inserts with d1 diameter by customer design, on request and for quantities.
- It is possible to supply the inserts with different treatment-finishes, on request and for quantities.
- It is possible to supply the inserts in different materials, on request and for quantities.
- It is possible to supply arm and handle with colours as shown in the table at page 15, on request and for quantities.

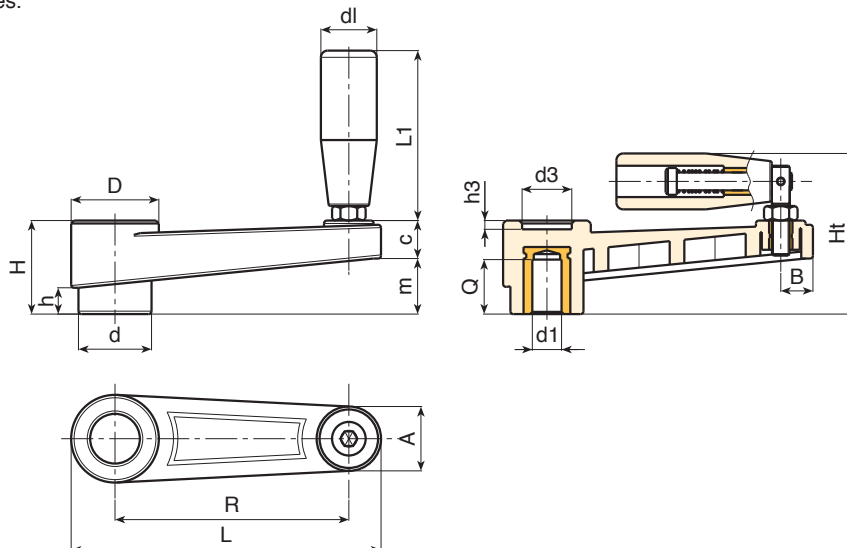

| Art.         | L   | R   | H  | Ht   | D  | d    | m  | c    | A    | B    | h    | d3   | h3  | dm | d1 H7  | Q  | dl | L1 | Weight (gr) |
|--------------|-----|-----|----|------|----|------|----|------|------|------|------|------|-----|----|--------|----|----|----|-------------|
| E217-65 D05  | 88  | 65  | 30 | 54   | 26 | 22   | 17 | 13   | 18   | 9,5  | 8    | 15   | 3   | 12 | D05 H9 | 20 | 20 | 54 | 105         |
| E217-65 D10  | 88  | 65  | 30 | 54   | 26 | 22   | 17 | 13   | 18   | 9,5  | 8    | 15   | 3   | 12 | D10    | 20 | 20 | 54 | 100         |
| E217-80 D05  | 106 | 80  | 33 | 57   | 30 | 26   | 19 | 13   | 21,5 | 11   | 9    | 17   | 3   | 14 | D05 H9 | 20 | 20 | 54 | 115         |
| E217-80 D10  | 106 | 80  | 33 | 57   | 30 | 26   | 19 | 13   | 21,5 | 11   | 9    | 17   | 3   | 14 | D10    | 20 | 20 | 54 | 110         |
| E217-110 D05 | 138 | 110 | 39 | 67,5 | 33 | 28,5 | 22 | 14   | 22   | 12   | 11   | 21   | 3,5 | 14 | D05 H9 | 22 | 25 | 75 | 156         |
| E217-110 D12 | 138 | 110 | 39 | 67,5 | 33 | 28,5 | 22 | 14   | 22   | 12   | 11   | 21   | 3,5 | 14 | D12    | 22 | 25 | 75 | 156         |
| E217-140 D05 | 173 | 140 | 49 | 82   | 43 | 35   | 34 | 16   | 25,5 | 13,5 | 15   | 27   | 3   | 20 | D05 H9 | 22 | 26 | 89 | 300         |
| E217-140 D14 | 173 | 140 | 49 | 82   | 43 | 35   | 34 | 16   | 25,5 | 13,5 | 15   | 27   | 3   | 20 | D14    | 22 | 26 | 89 | 240         |
| E217-185 D05 | 219 | 180 | 54 | 88   | 46 | 39   | 40 | 16,5 | 26,5 | 14   | 16,5 | 27,5 | 4   | 24 | D05 H9 | 26 | 26 | 97 | 450         |
| E217-185 D16 | 219 | 180 | 54 | 88   | 46 | 39   | 40 | 16,5 | 26,5 | 14   | 16,5 | 27,5 | 4   | 24 | D16    | 26 | 26 | 97 | 430         |

It's possible to increase the hole, by boring, until **dm**.

# ART. E518

## INDEXED CRANK HANDLE WITH THREADED INSERT AND REVOLVING HANDLE

**MATERIAL:**

Reinforced polyamide.  
Oils and greases resistant.

**SURFACE:**

Satin.

**COLOUR:**

Black (RAL 9011).

**MAIN INSERT:**

Zinc plated steel blind threaded bush.

**SIDE INSERT:**

Brass right through threaded bush.

**SPRING:**

Zinc plated steel spring.

**FIXING SCREW:**

Black-oxide treated screw with head for fitting screwdriver.

**SIDE HANDLE:**

Revolving handle Art. M144 (see chapter M on page 6).



**SPECIAL REQUESTS:**

- It is possible to supply the inserts in different materials, on request and for quantities.
- It is possible to supply arm and handle with colours as shown in the table at page 15, on request and for quantities.

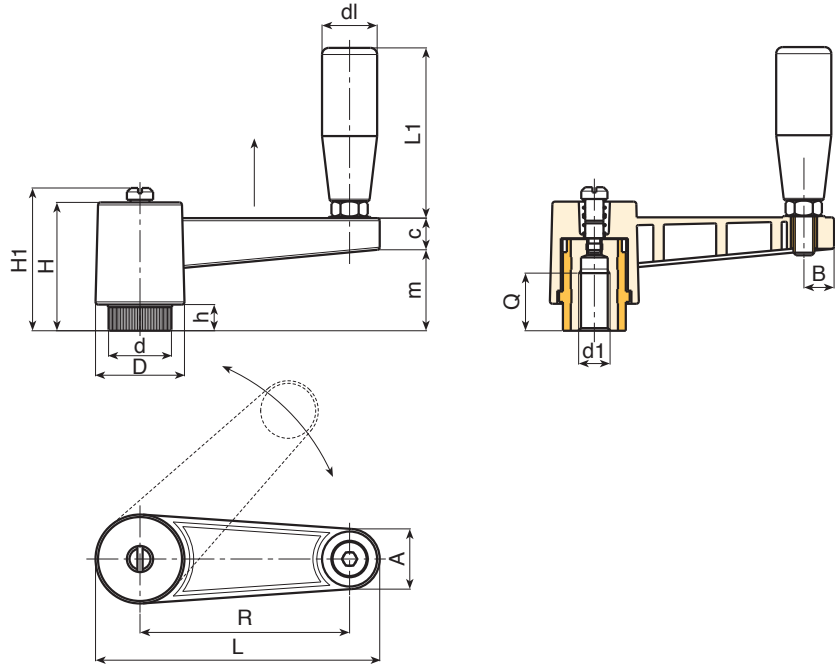

| Art.         | L   | R   | H  | D  | d    | m  | c  | A  | B    | h    | H1 | d1  | Q  | dl | L1 | Weight (gr) |
|--------------|-----|-----|----|----|------|----|----|----|------|------|----|-----|----|----|----|-------------|
| E518-65 M08  | 86  | 65  | 46 | 27 | 19   | 29 | 13 | 17 | 9    | 10   | -  | M08 | 18 | 20 | 56 | 94          |
| E518-65 M10  | 86  | 65  | 46 | 27 | 19   | 29 | 13 | 17 | 9    | 10   | -  | M10 | 17 | 20 | 56 | 90          |
| E518-65 M12  | 86  | 65  | 46 | 27 | 19   | 29 | 13 | 17 | 9    | 10   | -  | M12 | 17 | 20 | 56 | 90          |
| E518-80 M12  | 108 | 80  | 50 | 34 | 24   | 32 | 13 | 22 | 11,5 | 10,5 | 53 | M12 | 22 | 21 | 66 | 172         |
| E518-80 M14  | 108 | 80  | 50 | 34 | 24   | 32 | 13 | 22 | 11,5 | 10,5 | 53 | M14 | 23 | 21 | 66 | 164         |
| E518-80 M16  | 108 | 80  | 50 | 34 | 24   | 32 | 13 | 22 | 11,5 | 10,5 | 53 | M16 | 20 | 21 | 66 | 154         |
| E518-110 M12 | 138 | 110 | 50 | 34 | 24,5 | 33 | 13 | 22 | 11,5 | 11   | 54 | M12 | 20 | 21 | 66 | 181         |
| E518-110 M14 | 138 | 110 | 50 | 34 | 24,5 | 33 | 13 | 22 | 11,5 | 11   | 54 | M14 | 20 | 21 | 66 | 195         |
| E518-110 M16 | 138 | 110 | 50 | 34 | 24,5 | 33 | 13 | 22 | 11,5 | 11   | 54 | M16 | 20 | 21 | 66 | 198         |



## ART. E513

### INDEXED CRANK HANDLE WITH THREADED INSERT AND REVOLVING HANDLE M145



**MATERIAL:**

Reinforced polyamide.  
Oils and greases resistant.

**SURFACE:**

Satin.

**COLOUR:**

Black (RAL 9011).

**MAIN INSERT:**

Zinc plated steel blind threaded bush.

**SIDE INSERT:**

Brass right through threaded bush.

**SPRING:**

Zinc plated steel spring.

**FIXING SCREW:**

Black-oxide treated screw with head for fitting screwdriver.

**SIDE HANDLE:**

Revolving handle Art. M145 (see chapter M on page 8).

**SPECIAL REQUESTS:**

- It is possible to supply the inserts in different materials, on request and for quantities.
- It is possible to supply arm and handle with colours as shown in the table at page 15, on request and for quantities.

| Art.         | L   | R   | H  | D  | d    | m  | c  | A  | B    | h    | H1 | d1  | Q  | dl | L1 | Weight (gr) |
|--------------|-----|-----|----|----|------|----|----|----|------|------|----|-----|----|----|----|-------------|
| E513-65 M08  | 86  | 65  | 46 | 27 | 19   | 29 | 13 | 17 | 9    | 10   | -  | M08 | 18 | 20 | 56 | 96          |
| E513-65 M10  | 86  | 65  | 46 | 27 | 19   | 29 | 13 | 17 | 9    | 10   | -  | M10 | 17 | 20 | 56 | 92          |
| E513-65 M12  | 86  | 65  | 46 | 27 | 19   | 29 | 13 | 17 | 9    | 10   | -  | M12 | 17 | 20 | 56 | 91          |
| E513-80 M12  | 108 | 80  | 50 | 34 | 24,5 | 32 | 13 | 22 | 11,5 | 10,5 | 53 | M12 | 22 | 23 | 66 | 177         |
| E513-80 M14  | 108 | 80  | 50 | 34 | 24,5 | 32 | 13 | 22 | 11,5 | 10,5 | 53 | M14 | 23 | 23 | 66 | 179         |
| E513-80 M16  | 108 | 80  | 50 | 34 | 24,5 | 32 | 13 | 22 | 11,5 | 10,5 | 53 | M16 | 20 | 23 | 66 | 169         |
| E513-110 M12 | 138 | 110 | 50 | 34 | 24,5 | 33 | 13 | 22 | 11,5 | 11   | 54 | M12 | 20 | 23 | 66 | 196         |
| E513-110 M14 | 138 | 110 | 50 | 34 | 24,5 | 33 | 13 | 22 | 11,5 | 11   | 54 | M14 | 20 | 23 | 66 | 200         |
| E513-110 M16 | 138 | 110 | 50 | 34 | 24,5 | 33 | 13 | 22 | 11,5 | 11   | 54 | M16 | 20 | 23 | 66 | 205         |

## ART. E517

### INDEXED CRANK HANDLE WITH THREADED INSERT AND REVOLVING HANDLE M129



**MATERIAL:**

Reinforced polyamide.  
Oils and greases resistant.

**SURFACE:**

Satin.

**COLOUR:**

Black (RAL 9011).

**MAIN INSERT:**

Zinc plated steel blind threaded bush.

**SIDE INSERT:**

Brass right through threaded bush.

**SPRING:**

Zinc plated steel spring.

**FIXING SCREW:**

Black-oxide treated screw with head for fitting screwdriver.

**SIDE HANDLE:**

Revolving handle Art. M129 (see chapter M on page 9).

**SPECIAL REQUESTS:**

- It is possible to supply the inserts in different materials, on request and for quantities.
- It is possible to supply arm and handle with colours as shown in the table at page 15, on request and for quantities.

| Art.         | L   | R   | H  | D  | d    | m  | c  | A  | B    | h    | H1 | d1  | Q  | dl | L1 | Weight (gr) |
|--------------|-----|-----|----|----|------|----|----|----|------|------|----|-----|----|----|----|-------------|
| E517-65 M08  | 86  | 65  | 46 | 27 | 19   | 29 | 13 | 17 | 9    | 9,5  | -  | M08 | 18 | 20 | 52 | 106         |
| E517-65 M10  | 86  | 65  | 46 | 27 | 19   | 29 | 13 | 17 | 9    | 9,5  | -  | M10 | 17 | 20 | 52 | 102         |
| E517-65 M12  | 86  | 65  | 46 | 27 | 19   | 29 | 13 | 17 | 9    | 9,5  | -  | M12 | 17 | 20 | 52 | 102         |
| E517-80 M12  | 108 | 80  | 50 | 34 | 24,5 | 32 | 13 | 22 | 11,5 | 10,5 | 53 | M12 | 22 | 23 | 62 | 187         |
| E517-80 M14  | 108 | 80  | 50 | 34 | 24,5 | 32 | 13 | 22 | 11,5 | 10,5 | 53 | M14 | 23 | 23 | 62 | 189         |
| E517-80 M16  | 108 | 80  | 50 | 34 | 24,5 | 32 | 13 | 22 | 11,5 | 10,5 | 53 | M16 | 20 | 23 | 62 | 179         |
| E517-110 M12 | 138 | 110 | 50 | 34 | 24,5 | 33 | 13 | 22 | 11,5 | 11   | 54 | M12 | 20 | 23 | 62 | 206         |
| E517-110 M14 | 138 | 110 | 50 | 34 | 24,5 | 33 | 13 | 22 | 11,5 | 11   | 54 | M14 | 20 | 23 | 62 | 198         |
| E517-110 M16 | 138 | 110 | 50 | 34 | 24,5 | 33 | 13 | 22 | 11,5 | 11   | 54 | M16 | 20 | 23 | 62 | 196         |

# ART. E519

## INDEXED CRANK HANDLE WITH THREADED INSERT AND REVOLVING AND FOLDING HANDLE

**MATERIAL:**

Reinforced polyamide.  
Oils and greases resistant.

**SURFACE:**

Satin.

**COLOUR:**

Black (RAL 9011).

**MAIN INSERT:**

Zinc plated steel blind threaded bush.

**SIDE INSERT:**

Brass right through threaded bush.

**SPRING:**

Zinc plated steel spring.

**FIXING SCREW:**

Black-oxide treated screw with head for fitting screwdriver.

**SIDE HANDLE:**

Revolving handle and folding Art. M136 (see chapter M on page 10).



**SPECIAL REQUESTS:**

- It is possible to supply the inserts in different materials, on request and for quantities.
- It is possible to supply arm and handle with colours as shown in the table at page 15, on request and for quantities.

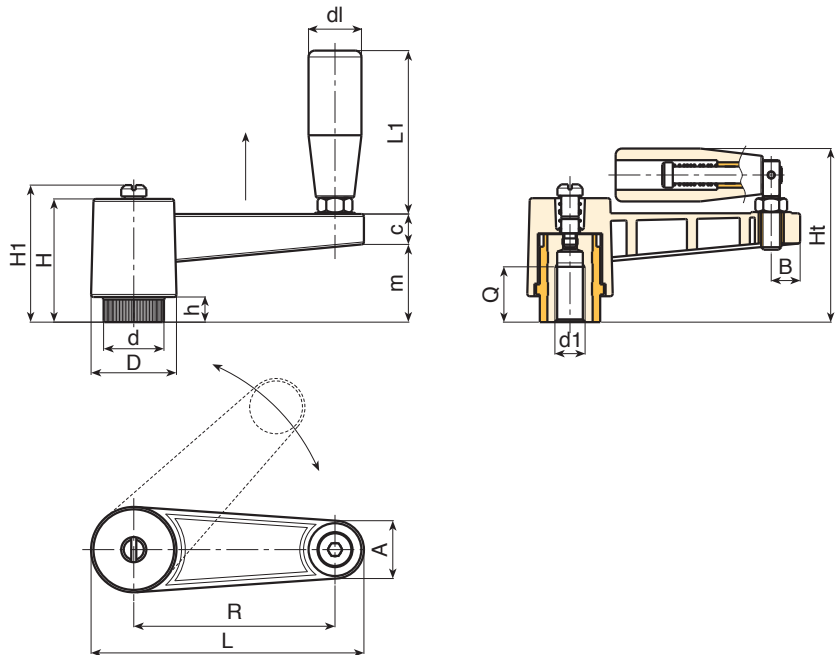

| Art.         | L   | R   | H  | D  | d    | m  | c  | A  | B    | h    | H1 | Ht   | d1  | Q  | dl | L1 | Weight (gr) |
|--------------|-----|-----|----|----|------|----|----|----|------|------|----|------|-----|----|----|----|-------------|
| E519-65 M08  | 86  | 65  | 46 | 27 | 19   | 29 | 13 | 17 | 9    | 10   | -  | 66,5 | M08 | 18 | 20 | 54 | 104         |
| E519-65 M10  | 86  | 65  | 46 | 27 | 19   | 29 | 13 | 17 | 9    | 10   | -  | 66,5 | M10 | 17 | 20 | 54 | 102         |
| E519-65 M12  | 86  | 65  | 46 | 27 | 19   | 29 | 13 | 17 | 9    | 10   | -  | 66,5 | M12 | 17 | 20 | 54 | 100         |
| E519-80 M12  | 108 | 80  | 50 | 34 | 24,5 | 32 | 13 | 22 | 11,5 | 10,5 | 53 | 75   | M12 | 22 | 25 | 75 | 185         |
| E519-80 M14  | 108 | 80  | 50 | 34 | 24,5 | 32 | 13 | 22 | 11,5 | 10,5 | 53 | 75   | M14 | 23 | 25 | 75 | 180         |
| E519-80 M16  | 108 | 80  | 50 | 34 | 24,5 | 32 | 13 | 22 | 11,5 | 10,5 | 53 | 75   | M16 | 20 | 25 | 75 | 174         |
| E519-110 M12 | 138 | 110 | 50 | 34 | 24,5 | 33 | 13 | 22 | 11,5 | 11   | 53 | 75   | M12 | 20 | 25 | 75 | 199         |
| E519-110 M14 | 138 | 110 | 50 | 34 | 24,5 | 33 | 13 | 22 | 11,5 | 11   | 53 | 75   | M14 | 20 | 25 | 75 | 220         |
| E519-110 M16 | 138 | 110 | 50 | 34 | 24,5 | 33 | 13 | 22 | 11,5 | 11   | 53 | 75   | M16 | 20 | 25 | 75 | 225         |

# ART. E520

## INDEXED CRANK HANDLE WITH SMOOTH INSERT AND REVOLVING HANDLE

**MATERIAL:**

Reinforced polyamide.  
Oils and greases resistant.

**SURFACE:**

Satin.

**COLOUR:**

Black (RAL 9011).

**MAIN INSERT:**

Zinc plated steel blind bored bush with H7 tolerance.

**SIDE INSERT:**

Brass right through threaded bush.

**SPRING:**

Zinc plated steel spring.

**FIXING SCREW:**

Black-oxide treated screw with head for fitting screwdriver.

**SIDE HANDLE:**

Revolving handle Art. M144 (see chapter M on page 6).

**SPECIAL REQUESTS:**

- It is possible to supply the inserts in different materials, on request and for quantities.
- It is possible to supply arm and handle with colours as shown in the table at page 15, on request and for quantities.

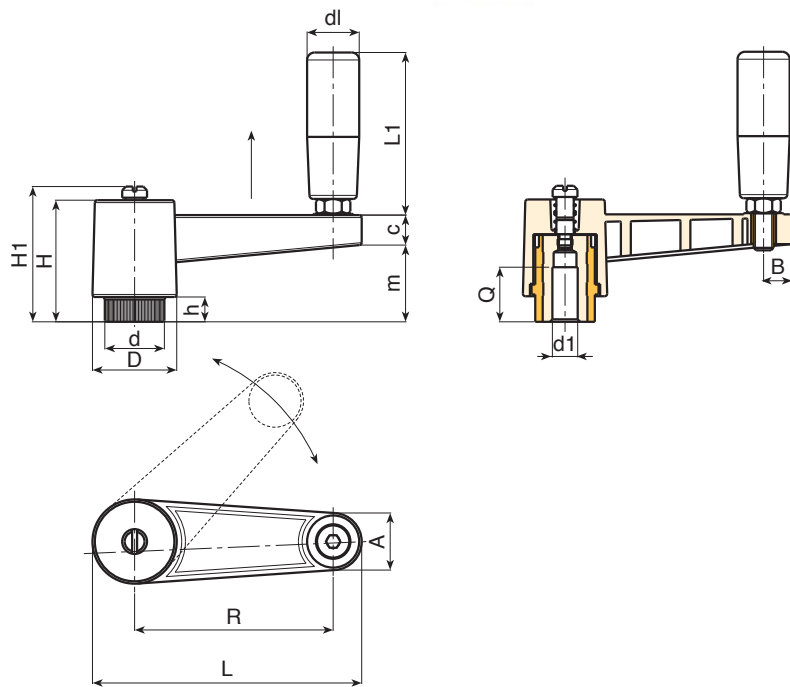

| Art.         | L   | R   | H  | D  | d    | m  | c  | A  | B    | h    | H1 | d1 H7 | Q  | dl   | L1 | Weight (gr) |
|--------------|-----|-----|----|----|------|----|----|----|------|------|----|-------|----|------|----|-------------|
| E520-65 D08  | 86  | 65  | 46 | 27 | 19   | 29 | 13 | 17 | 9    | 10   | -  | D08   | 22 | 20   | 56 | 83          |
| E520-80 D10  | 108 | 80  | 50 | 34 | 24,5 | 32 | 13 | 22 | 11,5 | 10,5 | 53 | D10   | 24 | 21,5 | 66 | 177         |
| E520-80 D12  | 108 | 80  | 50 | 34 | 24,5 | 32 | 13 | 22 | 11,5 | 10,5 | 53 | D12   | 23 | 21,5 | 66 | 174         |
| E520-110 D12 | 138 | 110 | 50 | 34 | 24,5 | 33 | 13 | 22 | 11,5 | 11   | 54 | D12   | 28 | 21,5 | 66 | 200         |
| E520-110 D14 | 138 | 110 | 50 | 34 | 24,5 | 33 | 13 | 22 | 11,5 | 11   | 54 | D14   | 26 | 21,5 | 66 | 210         |

## ART. E511

### INDEXED CRANK HANDLE WITH SMOOTH INSERT AND REVOLVING HANDLE M145



**MATERIAL:**

Reinforced polyamide.  
Oils and greases resistant.

**SURFACE:**

Satin.

**COLOUR:**

Black (RAL 9011).

**MAIN INSERT:**

Zinc plated steel blind bored bush with H7 tolerance.

**SIDE INSERT:**

Brass right through threaded bush.

**SPRING:**

Zinc plated steel spring.

**FIXING SCREW:**

Black-oxide treated screw with head for fitting screwdriver.

**SIDE HANDLE:**

Revolving handle Art. M145  
(see chapter M on page 8).

**SPECIAL REQUESTS:**

- It is possible to supply the inserts in different materials, on request and for quantities.
- It is possible to supply arm and handle with colours as shown in the table at page 15, on request and for quantities.

| Art.         | L   | R   | H  | D  | d    | m  | c  | A  | B    | h    | H1 | d1 H7 | Q  | dl | L1 | Weight (gr) |
|--------------|-----|-----|----|----|------|----|----|----|------|------|----|-------|----|----|----|-------------|
| E511-65 D08  | 86  | 65  | 46 | 27 | 19   | 29 | 13 | 17 | 9    | 10   | -  | D08   | 22 | 20 | 56 | 92          |
| E511-80 D10  | 108 | 80  | 50 | 34 | 24,5 | 32 | 13 | 22 | 11,5 | 10,5 | 53 | D10   | 24 | 23 | 66 | 187         |
| E511-80 D12  | 108 | 80  | 50 | 34 | 24,5 | 32 | 13 | 22 | 11,5 | 10,5 | 53 | D12   | 23 | 23 | 66 | 184         |
| E511-110 D12 | 138 | 110 | 50 | 34 | 24,5 | 33 | 13 | 22 | 11,5 | 11   | 54 | D12   | 28 | 23 | 66 | 205         |
| E511-110 D14 | 138 | 110 | 50 | 34 | 24,5 | 33 | 13 | 22 | 11,5 | 11   | 54 | D14   | 26 | 23 | 66 | 215         |

## ART. E516

### INDEXED CRANK HANDLE WITH SMOOTH INSERT AND REVOLVING HANDLE M129



**MATERIAL:**

Reinforced polyamide.  
Oils and greases resistant.

**SURFACE:**

Satin.

**COLOUR:**

Black (RAL 9011).

**MAIN INSERT:**

Zinc plated steel blind bored bush with H7 tolerance.

**SIDE INSERT:**

Brass right through threaded bush.

**SPRING:**

Zinc plated steel spring.

**FIXING SCREW:**

Black-oxide treated screw with head for fitting screwdriver.

**SIDE HANDLE:**

Revolving handle Art. M129  
(see chapter M on page 9).

**SPECIAL REQUESTS:**

- It is possible to supply the inserts in different materials, on request and for quantities.
- It is possible to supply arm and handle with colours as shown in the table at page 15, on request and for quantities.

| Art.         | L   | R   | H  | D  | d    | m  | c  | A  | B    | h    | H1 | d1 H7 | Q  | dl | L1 | Weight (gr) |
|--------------|-----|-----|----|----|------|----|----|----|------|------|----|-------|----|----|----|-------------|
| E516-65 D08  | 86  | 65  | 46 | 27 | 19   | 29 | 13 | 17 | 9    | 10   | -  | D08   | 22 | 20 | 52 | 95          |
| E516-80 D10  | 108 | 80  | 50 | 34 | 24,5 | 32 | 13 | 22 | 11,5 | 10,5 | 53 | D10   | 24 | 23 | 62 | 197         |
| E516-80 D12  | 108 | 80  | 50 | 34 | 24,5 | 32 | 13 | 22 | 11,5 | 10,5 | 53 | D12   | 23 | 23 | 62 | 194         |
| E516-110 D12 | 138 | 110 | 50 | 34 | 24,5 | 33 | 13 | 22 | 11,5 | 11   | 54 | D12   | 28 | 23 | 62 | 207         |
| E516-110 D14 | 138 | 110 | 50 | 34 | 24,5 | 33 | 13 | 22 | 11,5 | 11   | 54 | D14   | 26 | 23 | 62 | 218         |

# ART. E521

## INDEXED CRANK HANDLE WITH SMOOTH INSERT AND REVOLVING AND FOLDING HANDLE

**MATERIAL:**

Reinforced polyamide.  
Oils and greases resistant.

**SURFACE:**

Satin.

**COLOUR:**

Black (RAL 9011).

**MAIN INSERT:**

Zinc plated steel blind bored bush with H7 tolerance.

**SIDE INSERT:**

Brass right through threaded bush.

**SPRING:**

Zinc plated steel spring.

**FIXING SCREW:**

Black-oxide treated screw with head for fitting screwdriver.

**SIDE HANDLE:**

Revolving handle and folding Art. M136 (see chapter M on page 10).



**SPECIAL REQUESTS:**

- It is possible to supply the inserts in different materials, on request and for quantities.
- It is possible to supply arm and handle with colours as shown in the table at page 15, on request and for quantities.

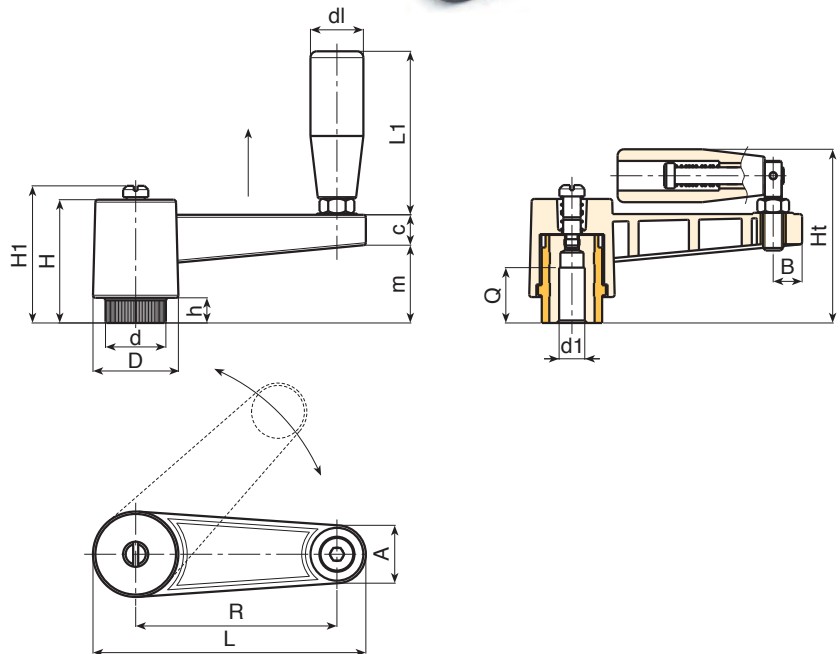

| Art.         | L   | R   | H  | D  | d    | m  | c  | A  | B    | h    | H1 | Ht   | d1 H7 | Q  | dl | L1 | Weight (gr) |
|--------------|-----|-----|----|----|------|----|----|----|------|------|----|------|-------|----|----|----|-------------|
| E521-65 D08  | 86  | 65  | 46 | 27 | 19   | 29 | 13 | 17 | 9    | 10   | -  | 66,5 | D08   | 22 | 20 | 54 | 105         |
| E521-80 D10  | 108 | 80  | 50 | 34 | 24,5 | 32 | 13 | 22 | 11,5 | 10,5 | 53 | 75   | D10   | 24 | 25 | 75 | 190         |
| E521-80 D12  | 108 | 80  | 50 | 34 | 24,5 | 32 | 13 | 22 | 11,5 | 10,5 | 53 | 75   | D12   | 23 | 25 | 75 | 188         |
| E521-110 D12 | 138 | 110 | 50 | 34 | 24,5 | 33 | 13 | 22 | 11,5 | 11   | 54 | 75   | D12   | 28 | 25 | 75 | 220         |
| E521-110 D14 | 138 | 110 | 50 | 34 | 24,5 | 33 | 13 | 22 | 11,5 | 11   | 54 | 75   | D14   | 26 | 25 | 75 | 225         |











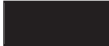





**E – FIXED AND  
INDEXED CRANK HANDLES**

© ROLLMEX - Reproduction prohibited













 **ROLLMEX**

# COLOUR CHART

## R A L

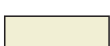
| COLOUR |                                                                                     | RAL  | CODE |
|--------|-------------------------------------------------------------------------------------|------|------|
| Black  |    | 9011 | 01   |
| Orange |    | 2004 | 02   |
| Orange |    | 2011 | 03   |
| White  |    | 9010 | 04   |
| Blue   |    | 5002 | 05   |
| Blue   |    | 5005 | 06   |
| Blue   |  | 5015 | 07   |
| Blue   |  | 5018 | 19   |
| Blue   |  | 5019 | 21   |
| Blue   |  | 5010 | 22   |
| Yellow |  | 1007 | 09   |
| Yellow |  | 1021 | 10   |
| Grey   |  | 7024 | 12   |
| Grey   |  | 7035 | 13   |
| Red    |  | 3000 | 16   |
| Green  |  | 6024 | 17   |

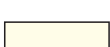
## O T H E R C O L O U R S

| COLOUR  |                                                                                       | REF.        | CODE |
|---------|---------------------------------------------------------------------------------------|-------------|------|
| White   |    | -           | 52   |
| Blue    |    | -           | 53   |
| Blue    |    | pant. 645 U | 54   |
| Blue    |    | pant. 300   | 55   |
| Grey    |    | -           | 57   |
| Grey    |    | -           | 59   |
| Grey    |  | NCS 7500    | 60   |
| Red     |  | -           | 64   |
| Red     |  | -           | 65   |
| Natural |  | -           | 66   |
| Green   |  | -           | 70   |
| Brown   |  | -           | 71   |
| Cream   |  | -           | 72   |
| Violet  |  | -           | 73   |



**WWW.ROLLMEX.FI**

**ROLLMEX Oy**

Takojankatu 4 - 33540 TAMPERE  
Push. 010-6661122 - Fax 03-3640072  
tamper@rollmex.fi

---

Karjalankatu 21 - 15140 LAHTI  
Push. 010-6661121 - Fax 03-7511026  
lahti@rollmex.fi

AUTHORISED RESELLER