

**C – FAMILY
SOLID CONTROL
HANDWHEELS**



 **ROLLMEX**

ART. C196

SOLID CONTROL HANDWHEEL

MATERIAL:

Reinforced and stabilised polyamide.
Oils and greases resistant.

SURFACE:

Satin.

COLOUR:

Black (RAL 9011).

CENTRAL CAP:

Grey polyamide (RAL 7035 code 13).

ALTERNATIVE CAP COLOUR:

Orange (RAL 2004 code 02).
Blue (RAL 5015 code 07).
Yellow (RAL 1021 code 10).
Red (RAL 3000 code 16).
Green (RAL 6024 code 17).
Black (RAL 9011 code 01).

MAIN INSERT:

Zinc plated steel right through bored bush
with H7 tolerance.

For fixing systems, or execution of tabs
or square holes, please refer to the technical
notes attached to the catalogue.

SPECIAL REQUESTS:

- It is possible to supply the inserts with d1 diameter by customer design, on request and for quantities.
- It is possible to supply the inserts in different materials, on request and for quantities.
- It is possible to supply the inserts with different treatment-finishes, on request and for quantities.
- It is possible to supply the complete handwheels with colours as shown in the table at page 11, on request and for quantities.

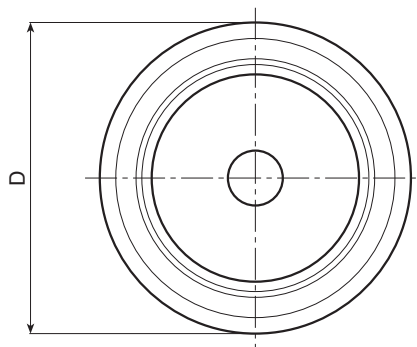
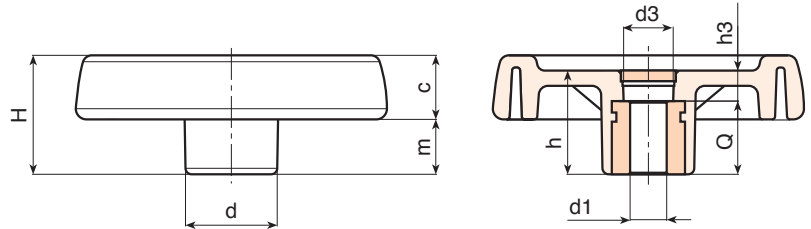

Art.	D	H	h	d	m	c	d3	h3	d1 H7	Q	dm	Weight (gr)
C196-80 D05	81	33	29	25	16	17	16	9	5 H9	20	12	100
C196-80 D10	81	33	29	25	16	17	16	9	10	20	12	100
C196-100 D05	100	39	34	30	18,5	20,5	16	10	5 H9	24	16	192
C196-100 D10	100	39	34	30	18,5	20,5	16	10	10	24	16	190
C196-125 D05	125	44	37	36	20	24	26	13	5 H9	24	18	295
C196-125 D12	125	44	37	36	20	24	26	13	12	24	18	290
C196-150 D05	150	54	44	38	25	29	26	12	5 H9	32	22	520
C196-150 D14	150	54	44	38	25	29	26	12	14	32	22	505
C196-175 D05	173	57	47	40	25,5	31,5	26	15	5 H9	32	22	660
C196-175 D16	173	57	47	40	25,5	31,5	26	15	16	32	22	650
C196-200 D05	202	59	49	44	24	35	27	13	5 H9	36	28	870
C196-200 D20	202	59	49	44	24	35	27	13	20	36	28	855
C196-250 D05	249	68	58	59	29	39	36	22	5 H9	36	28	1420
C196-250 D20	249	68	58	59	29	39	36	22	20	36	28	1400

It's possible to increase the hole, by boring, until dm.

**C – SOLID CONTROL
HANDWHEELS**

ROLLMEX

ART. C198

SOLID CONTROL HANDWHEEL WITH REVOLVING FOLDING HANDLE

MATERIAL:

Reinforced and stabilised polyamide.
Oils and greases resistant.

SURFACE:

Satin.

HANDWHEEL AND HANDLE COLOUR:

Black (RAL 9011).

CENTRAL CAP:

Grey polyamide (RAL 7035 code 13).

ALTERNATIVE CAP COLOUR:

Orange (RAL 2004 code 02).
Blue (RAL 5015 code 07).
Yellow (RAL 1021 code 10).
Red (RAL 3000 code 16).
Green (RAL 6024 code 17).
Black (RAL 9011 code 01).

MAIN INSERT:

Zinc plated steel right through bored bush with H7 tolerance.

SIDE INSERT:

Brass right through threaded bush.

SIDE HANDLE:

Revolving handle and folding Art. M136 (see chapter M on page 10).

For fixing systems, or execution of tabs or square holes, please refer to the technical notes attached to the catalogue.

SPECIAL REQUESTS:

- It is possible to supply the inserts with d1 diameter by customer design, on request and for quantities.
- It is possible to supply the inserts in different materials, on request and for quantities.
- It is possible to supply the inserts with different treatment-finishes, on request and for quantities.
- It is possible to supply the complete handwheels with colours as shown in the table at page 11, on request and for quantities.

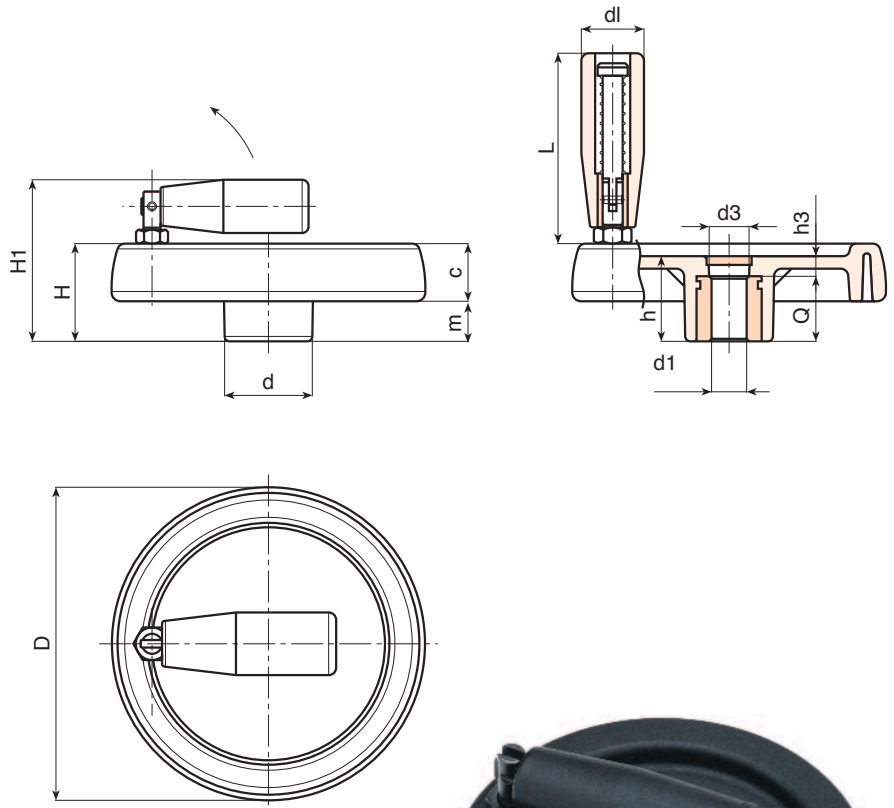

Art.	D	H	H1	h	d	m	c	d3	h3	d1 H7	Q	dm	dl	L	Weight (gr)
C198-80 D05	81	33	57	29	25	16	17	16	9	5 H9	20	12	20	56	145
C198-80 D10	81	33	57	29	25	16	17	16	9	10	20	12	20	56	142
C198-100 D05	100	39	63	34	30	18,5	20,5	16	10	5 H9	24	16	20	56	235
C198-100 D10	100	39	63	34	30	18,5	20,5	16	10	10	24	16	20	56	232
C198-125 D05	125	44	74	37	36	20	24	26	13	5 H9	24	18	25	76	360
C198-125 D12	125	44	74	37	36	20	24	26	13	12	24	18	25	76	355
C198-150 D05	150	54	89	44	38	25	29	26	12	5 H9	32	22	26	89	670
C198-150 D14	150	54	89	44	38	25	29	26	12	14	32	22	26	89	660
C198-175 D05	173	57	92	47	40	25,5	31,5	26	15	5 H9	32	22	26	97	810
C198-175 D16	173	57	92	47	40	25,5	31,5	26	15	16	32	22	26	97	800
C198-200 D05	202	59	94	49	44	24	35	27	13	5 H9	36	28	26	97	1030
C198-200 D20	202	59	94	49	44	24	35	27	13	20	36	28	26	97	1015
C198-250 D05	249	68	100	58	59	29	39	36	22	5 H9	36	28	26	97	1580
C198-250 D20	249	68	100	58	59	29	39	36	22	20	36	28	26	97	1567

It's possible to increase the hole, by boring, until dm.

ART. C197

SOLID CONTROL HANDWHEEL WITH REVOLVING HANDLE

MATERIAL:

Reinforced and stabilised polyamide.
Oils and greases resistant.

SURFACE:

Satin.

HANDWHEEL AND HANDLE COLOUR:

Black (RAL 9011).

CENTRAL CAP:

Grey polyamide (RAL 7035 code 13).

ALTERNATIVE CAP COLOUR:

Orange (RAL 2004 code 02).
Blue (RAL 5015 code 07).
Yellow (RAL 1021 code 10).
Red (RAL 3000 code 16).
Green (RAL 6024 code 17).
Black (RAL 9011 code 01).

MAIN INSERT:

Zinc plated steel right through bored bush with H7 tolerance.

SIDE INSERT:

Brass right through threaded bush.

SIDE HANDLE:

Revolving handle Art. M144
(see chapter M on page 6).

For fixing systems, or execution of tabs square holes, please refer to the technical notes attached to the catalogue.

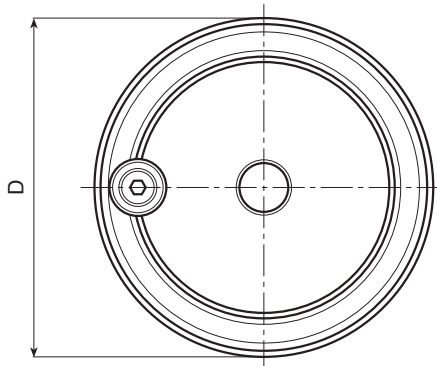
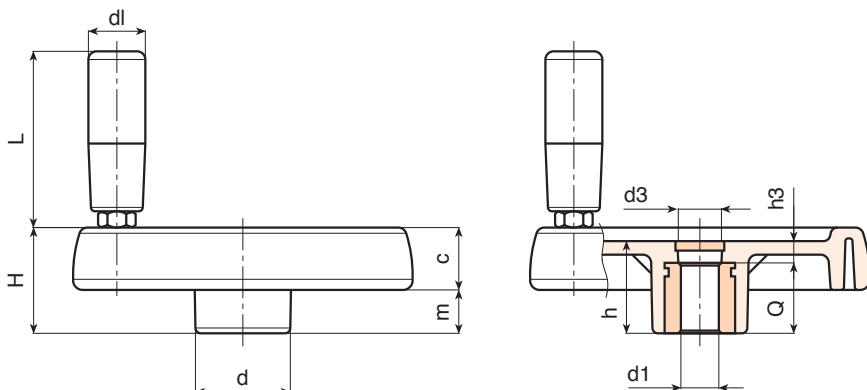

SPECIAL REQUESTS:

- It is possible to supply the inserts with d1 diameter by customer design, on request and for quantities.
- It is possible to supply the inserts in different materials, on request and for quantities.
- It is possible to supply the inserts with different treatment-finishes, on request and for quantities.
- It is possible to supply the complete handwheels with colours as shown in the table at page 11, on request and for quantities.

Art.	D	H	h	d	m	c	d3	h3	d1 H7	Q	dm	dl	L	Weight (gr)
C197-80 D05	81	33	29	25	16	17	16	9	5 H9	20	12	20	56	130
C197-80 D10	81	33	29	25	16	17	16	9	10	20	12	20	56	130
C197-100 D05	100	39	34	30	18,5	20,5	16	10	5 H9	24	16	20	56	192
C197-100 D10	100	39	34	30	18,5	20,5	16	10	10	24	16	20	56	190
C197-125 D05	125	44	37	36	20	24	26	13	5 H9	24	18	21	65	351
C197-125 D12	125	44	37	36	20	24	26	13	12	24	18	21	65	347
C197-150 D05	150	54	44	38	25	29	26	12	5 H9	32	22	23	76	588
C197-150 D14	150	54	44	38	25	29	26	12	14	32	22	23	76	573
C197-175 D05	173	57	47	40	25,5	31,5	26	15	5 H9	32	22	25	86	770
C197-175 D16	173	57	47	40	25,5	31,5	26	15	16	32	22	25	86	760
C197-200 D05	202	59	49	44	24	35	27	13	5 H9	36	28	25	86	980
C197-200 D20	202	59	49	44	24	35	27	13	20	36	28	25	86	965
C197-250 D05	249	68	58	59	29	39	36	22	5 H9	36	28	25	86	1530
C197-250 D20	249	68	58	59	29	39	36	22	20	36	28	25	86	1510

It's possible to increase the hole, by boring, until dm.

C – SOLID CONTROL
HANDWHEELS

ROLLMEX

OPTIONS



ART. C193



ART. C195



ART. C194



STANDARD ART. C SERIES

ART. C193

SOLID CONTROL HANDWHEEL REVOLVING HANDLE M145

Art.	D	d1	L	Weight (gr)	OTHER VALUES
C193-80	81	20	55	135	see table C197
C193-100	100	20	55	220	see table C197
C193-125	125	23	66	370	see table C197
C193-150	150	25	76	594	see table C197
C193-175	173	25	87	750	see table C197
C193-200	202	27	96	965	see table C197
C193-250	249	27	96	1500	see table C197

SIDE HANDLE:

Revolving handle Art. M145 (see chapter M page 8).

For details of the handwheel see those for art. C197.

ART. C194

SOLID CONTROL HANDWHEEL WITH REVOLVING HANDLE M129

Art.	D	d1	L	Weight (gr)	OTHER VALUES
C194-80	81	20	52	145	see table C197
C194-100	100	20	52	235	see table C197
C194-125	125	23	62	350	see table C197
C194-150	150	25	72	610	see table C197
C194-175	173	25	81	755	see table C197
C194-200	202	27	93	975	see table C197
C194-250	249	27	93	1520	see table C197

SIDE HANDLE:

Revolving handle Art. M129 (see chapter M page 9).

For details of the handwheel see those for art. C197.

ART. C195

SOLID CONTROL HANDWHEEL WITH REVOLVING HANDLE "EUROMODEL" M202

Art.	D	d1	L	Weight (gr)	OTHER VALUES
C195-150	150	40	64	610	see table C197
C195-175	173	40	64	750	see table C197
C195-200	202	40	64	960	see table C197
C195-250	249	40	64	1490	see table C197

SIDE HANDLE:

Revolving handle Art. M202 (see chapter M page 18).

For details of the handwheel see those for art. C197.

STANDARD ART. C SERIES

BASE FOR SOLID CONTROL HANDWHEEL WITH PROVISION FOR HANDLE

Art.	D	d1	side handle threading	Weight (gr)	OTHER VALUES
C80	81	5 H9	M6	100	see table C197
C100	100	5 H9	M6	190	see table C197
C125	125	5 H9	M8	290	see table C197
C150	150	5 H9	M10	520	see table C197
C175	173	5 H9	M10	660	see table C197
C200	202	5 H9	M10	870	see table C197
C250	249	5 H9	M10	1400	see table C197

This article is recommended for distributors.

For details of the handwheel see those for art. C197.

ART. C199

SOLID CONTROL HANDWHEEL WITH FOLDAWAY REVOLVING HANDLE

MATERIAL:

Reinforced and stabilised polyamide.
Oils and greases resistant.

SURFACE:

Satin.

HANDWHEEL AND HANDLE COLOUR:

Black (RAL 9011).

CENTRAL CAP:

Grey polyamide (RAL 7035 code 13).

MAIN INSERT:

Zinc plated steel right through bored bush with H7 tolerance.

SIDE HANDLE:

Flush, foldaway revolving handle, with hexagonal connection. Reinforced polyamide handle. Black-oxide treated internal mechanism. Fixed with black-oxide treated hexagon socket button head screw ISO 7838.

For fixing systems, or execution of tabs or square holes, please refer to the technical notes attached to the catalogue.

SPECIAL REQUESTS:

- It is possible to supply the inserts with d1 diameter by customer design, on request and for quantities.
- It is possible to supply the inserts in different materials, on request and for quantities.
- It is possible to supply the inserts with different treatment-finishes, on request and for quantities.
- It is possible to supply the complete handwheels with colours as shown in the table at page 11, on request and for quantities.

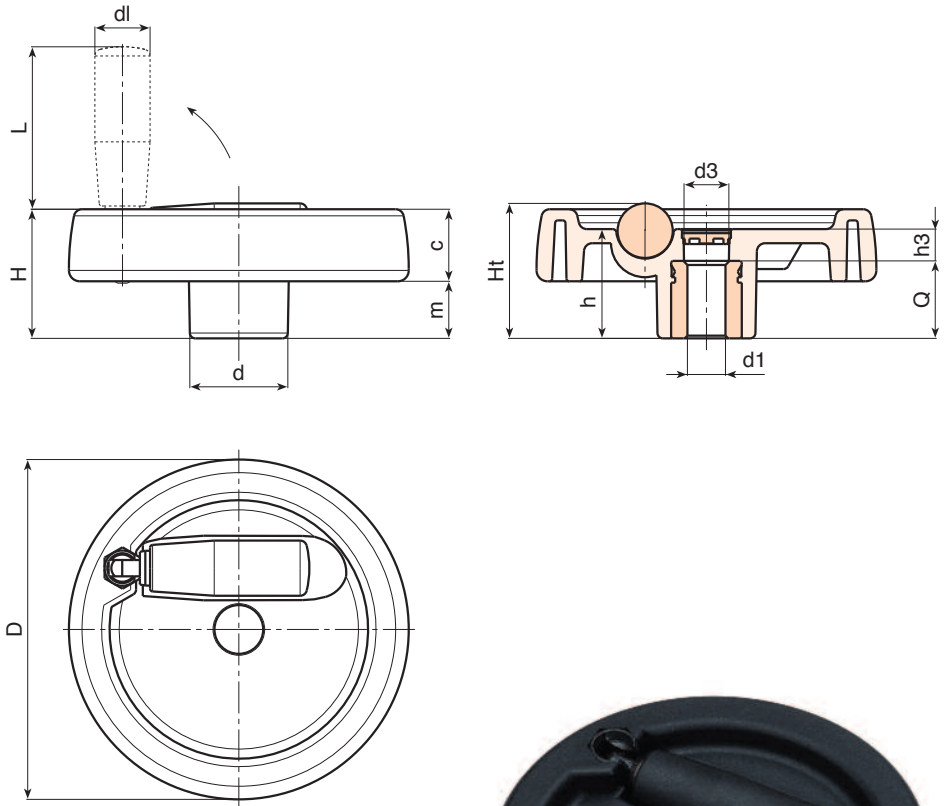

Art.	D	H	Ht	h	d	m	c	h3	d3	d1 H7	Q	dm	dl	L	Weight (gr)
C199-125 D05	124	48	49,5	40	36	21,5	26,5	16	15	5 H9	24	18	20	38	349
C199-125 D12	124	48	49,5	40	36	21,5	26,5	16	15	12	24	18	20	38	343
C199-150 D05	149	53	-	44	38	24,5	28,5	12	26	5 H9	32	22	20	58	500
C199-150 D14	149	53	-	44	38	24,5	28,5	12	26	14	32	22	20	58	492
C199-175 D05	174	58	-	48	40	24,5	33,5	16	26	5 H9	32	28	26	80	715
C199-175 D16	174	58	-	48	40	24,5	33,5	16	26	16	32	28	26	80	705
C199-200 D05	198	63	-	53	44	24,5	38,5	17	26	5 H9	36	28	27	90	1015
C199-200 D20	198	63	-	53	44	24,5	38,5	17	26	20	36	28	27	90	1000
C199-250 D05	250	67	-	58	60	29	38	22	36	5 H9	36	28	27	90	1500
C199-250 D20	250	67	-	58	60	29	38	22	36	20	36	28	27	90	1485

It's possible to increase the hole, by boring, until dm.

ART. C199

SOLID CONTROL HANDWHEEL WITH CENTRAL FOLDAWAY REVOLVING HANDLE

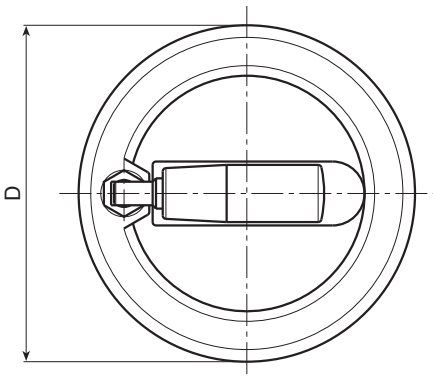
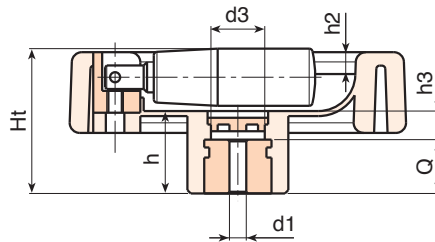
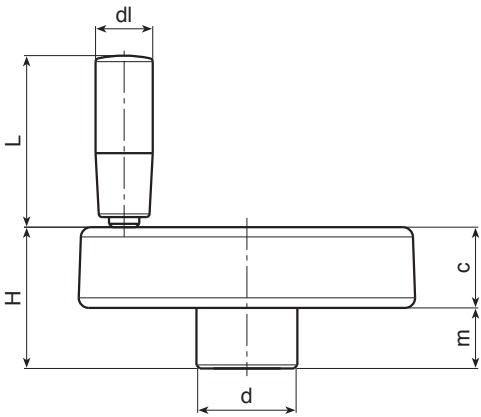

MATERIAL:

Reinforced and stabilised polyamide.
Oils and greases resistant.

SURFACE:

Satin.

HANDWHEEL AND HANDLE COLOUR:

Black (RAL 9011).

CENTRAL CAP:

Grey polyamide (RAL 7035 code 13).

MAIN INSERT:

Zinc plated steel right through bored bush with H7 tolerance.

SIDE HANDLE:

Flush, foldaway revolving handle, with hexagonal connection. Reinforced polyamide handle. Black-oxide treated internal mechanism. Fixed with black-oxide treated hexagon socket button head screw ISO 7838.

For fixing systems, or execution of tabs or square holes, please refer to the technical notes attached to the catalogue.

SPECIAL REQUESTS:

- It is possible to supply the inserts with d1 diameter by customer design, on request and for quantities.
- It is possible to supply the inserts in different materials, on request and for quantities.
- It is possible to supply the inserts with different treatment-finishes, on request and for quantities.
- It is possible to supply the complete handwheels with colours as shown in the table at page 11, on request and for quantities.

Art.	D	H	Ht	h	d	m	c	h2	h3	d3	d1 H7	Q	dm	dl	L	Weight (gr)
C199-80 D05	80	33	35	19	25	15	18	4	6	15	5 H9	13	12	16	38	113
C199-80 D10	80	33	35	19	25	15	18	4	6	15	10	13	12	16	38	110
C199-100 D05	100	42	43,5	24	30	18	24	6,5	8	17	5 H9	16	16	17	48	240
C199-100 D10	100	42	43,5	24	30	18	24	6,5	8	17	10	16	16	17	48	237

It's possible to increase the hole, by boring, until **dm**.

ART. C970

SOLID CONTROL HANDWHEEL WITH REVOLVING HANDLE AND LOCKING HANDWHEEL

MATERIAL:

Reinforced and stabilised polyamide.
Oils and greases resistant.

SURFACE:

Satin.

HANDWHEEL AND HANDLE COLOUR:

Black (RAL 9011).

CENTRAL CAP:

Grey polyamide (RAL 7035 code 13).

MAIN INSERT:

Zinc plated steel right through bored bush with H7 tolerance.

SIDE INSERT:

Brass right through threaded bush.

SIDE HANDLE:

Revolving handle Art. M144
(see chapter M on page 6).

LOCKING HANDWHEEL:

Cylindrical handwheel G793-36 with threaded stud (see chapter G page 12). Black (RAL 9011).

Caution: the R and Q2 dimensions of the handwheel must be chosen by the customer according to the dimensions of the machinery on which it will be installed.

For fixing systems, or execution of tabs or square holes, please refer to the technical notes attached to the catalogue.

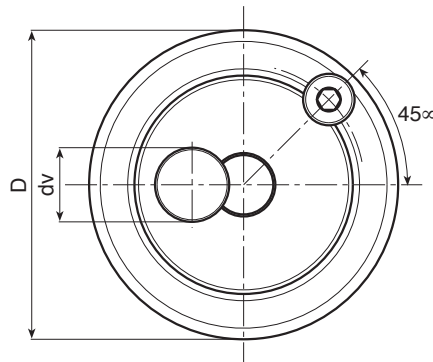
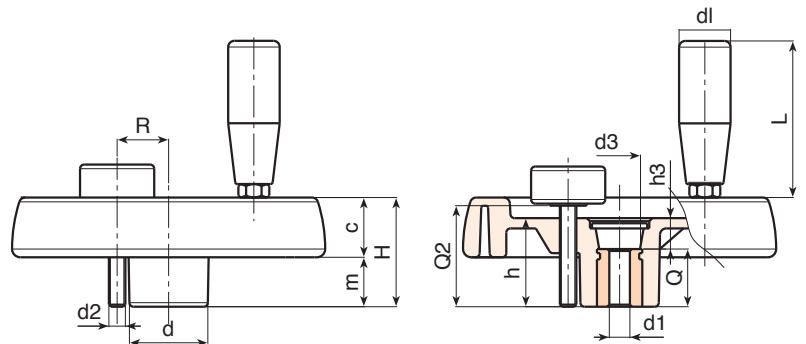

SPECIAL REQUESTS:

- It is possible to supply the inserts with d1 diameter by customer design, on request and for quantities.
- It is possible to supply the inserts in different materials, on request and for quantities.
- It is possible to supply the inserts with different treatment-finishes, on request and for quantities.
- It is possible to supply the complete handwheels with colours as shown in the table at page 11, on request and for quantities.

Art.	D	H	h	d	m	c	d3	h3	R	d2	Q2	d1 H7	Q	dm	dl	L	Weight (gr)
C970-100 D05	100	39	34	30	18,5	20,5	16	10	20	M6	A.R.	5 H9	24	16	20	56	252
C970-100 D10	100	39	34	30	18,5	20,5	16	10	20	M6	A.R.	10	24	16	20	56	250
C970-125 D05	125	44	37	36	20	24	26	13	22÷25	M6	A.R.	5 H9	24	18	21	65	410
C970-125 D12	125	44	37	36	20	24	26	13	22÷25	M6	A.R.	12	24	18	21	65	407
C970-150 D05	150	54	44	38	25	29	26	12	25÷28	M8	A.R.	5 H9	32	22	21	65	636
C970-150 D14	150	54	44	38	25	29	26	12	25÷28	M8	A.R.	14	32	22	21	65	625
C970-175 D05	173	57	47	40	25,5	31,5	26	15	26÷36	M8	A.R.	5 H9	32	22	23	76	812
C970-175 D16	173	57	47	40	25,5	31,5	26	15	26÷36	M8	A.R.	16	32	22	23	76	802
C970-200 D05	202	59	49	44	24	35	27	13	28÷42	M8	A.R.	5 H9	36	28	25	86	1040
C970-200 D20	202	59	49	44	24	35	27	13	28÷42	M8	A.R.	20	36	28	25	86	1025
C970-250 D05	249	68	58	59	29	39	36	22	36÷50	M8	A.R.	5 H9	36	28	25	86	1590
C970-250 D20	249	68	58	59	29	39	36	22	36÷50	M8	A.R.	20	36	28	25	86	1570

dv= 36 mm.

It's possible to increase the hole, by boring, until dm.

A.R.= Upon Request.

**C – SOLID CONTROL
HANDWHEELS**

ROLLMEX

ART. C980

SOLID CONTROL HANDWHEEL WITH REVOLVING FOLDING HANDLE AND LOCKING HANDWHEEL

MATERIAL:

Reinforced and stabilised polyamide.
Oils and greases resistant.

SURFACE:

Satin.

HANDWHEEL AND HANDLE COLOUR:

Black (RAL 9011).

CENTRAL CAP:

Grey polyamide (RAL 7035 code 13).

MAIN INSERT:

Zinc plated steel right through bored bush with H7 tolerance.

SIDE INSERT:

Brass right through threaded bush.

SIDE HANDLE:

Revolving handle and folding Art. M136 (see chapter M on page 10).

LOCKING HANDWHEEL:

Cylindrical handwheel G793-36 with threaded stud (see chapter G page 12). Black (RAL 9011).

Caution: the R and Q2 dimensions of the handwheel must be chosen by the customer according to the dimensions of the machinery on which it will be installed.

For fixing systems, or execution of tabs or square holes, please refer to the technical notes attached to the catalogue.

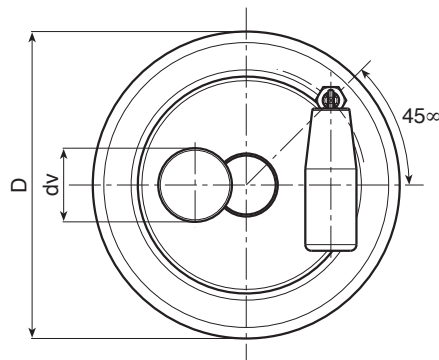
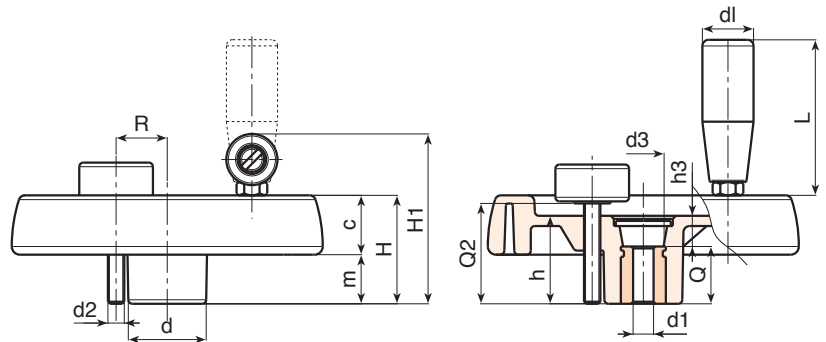

SPECIAL REQUESTS:

- It is possible to supply the inserts with d1 diameter by customer design, on request and for quantities.
- It is possible to supply the inserts in different materials, on request and for quantities.
- It is possible to supply the inserts with different treatment-finishes, on request and for quantities.
- It is possible to supply the complete handwheels with colours as shown in the table at page 11, on request and for quantities.

Art.	D	H	H1	h	d	m	c	d3	h3	R	d2	Q2	d1 H7	Q	dm	dl	L	Weight (gr)
C980-100 D05	100	39	63	34	30	18,5	20,5	16	10	20	M6	A.R.	5 H9	24	16	20	56	295
C980-100 D10	100	39	63	34	30	18,5	20,5	16	10	20	M6	A.R.	10	24	16	20	56	292
C980-125 D05	125	44	74	37	36	20	24	26	13	22÷25	M6	A.R.	5 H9	24	18	25	76	420
C980-125 D12	125	44	74	37	36	20	24	26	13	22÷25	M6	A.R.	12	24	18	25	76	415
C980-150 D05	150	54	89	44	38	25	29	26	12	25÷28	M8	A.R.	5 H9	32	22	26	89	730
C980-150 D14	150	54	89	44	38	25	29	26	12	25÷28	M8	A.R.	14	32	22	26	89	725
C980-175 D05	173	57	92	47	40	25,5	31,5	26	15	26÷36	M8	A.R.	5 H9	32	22	26	89	885
C980-175 D16	173	57	92	47	40	25,5	31,5	26	15	26÷36	M8	A.R.	16	32	22	26	89	875
C980-200 D05	202	59	94	49	44	24	35	27	13	28÷42	M8	A.R.	5 H9	36	28	26	97	1100
C980-200 D20	202	59	94	49	44	24	35	27	13	28÷42	M8	A.R.	20	36	28	26	97	1090
C980-250 D05	249	68	100	58	59	29	39	36	22	36÷50	M8	A.R.	5 H9	36	28	26	97	1640
C980-250 D20	249	68	100	58	59	29	39	36	22	36÷50	M8	A.R.	20	36	28	26	97	1627

dv= 36 mm.

It's possible to increase the hole, by boring, until dm.

A.R.= Upon Request.

ART. C990

SOLID CONTROL HANDWHEEL WITH FOLDAWAY REVOLVING HANDLE AND LOCKING HANDWHEEL

MATERIAL:

Reinforced and stabilised polyamide.
Oils and greases resistant.

SURFACE:

Satin.

HANDWHEEL AND HANDLE COLOUR:

Black (RAL 9011).

CENTRAL CAP:

Grey polyamide (RAL 7035 code 13).

MAIN INSERT:

Zinc plated steel right through bored bush with H7 tolerance.

SIDE HANDLE:

Flush, foldaway revolving handle, with hexagonal connection. Reinforced polyamide handle. Black-oxide treated internal mechanism. Fixed with black-oxide treated hexagon socket button head screw ISO 7838.

LOCKING HANDWHEEL:

Cylindrical handwheel G793-36 with threaded stud (see chapter G page 12). Black (RAL 9011).

Caution: the R and Q2 dimensions of the handwheel must be chosen by the customer according to the dimensions of the machinery on which it will be installed.

For fixing systems, or execution of tabs or square holes, please refer to the technical notes attached to the catalogue.

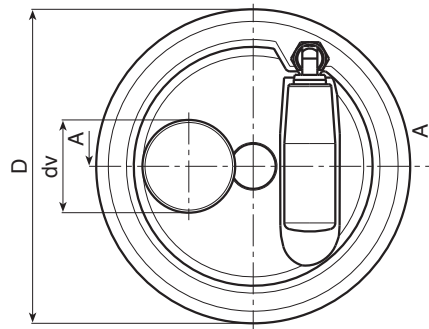
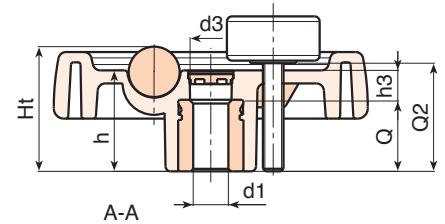
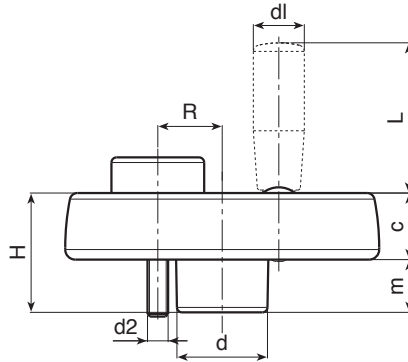

SPECIAL REQUESTS:

- It is possible to supply the inserts with d1 diameter by customer design, on request and for quantities.
- It is possible to supply the inserts in different materials, on request and for quantities.
- It is possible to supply the inserts with different treatment-finishes, on request and for quantities.
- It is possible to supply the complete handwheels with colours as shown in the table at page 11, on request and for quantities.

Art.	D	H	Ht	h	d	m	c	h3	d3	R	d2	Q2	d1 H7	Q	dm	dl	L	Weight (gr)
C990-125 D05	124	48	49,5	40	36	21,5	26,5	16	15	22÷25	M6	A.R.	5 H9	24	18	20	38	410
C990-125 D12	124	48	49,5	40	36	21,5	26,5	16	15	22÷25	M6	A.R.	12	24	18	20	38	408
C990-150 D05	149	53	-	44	38	24,5	28,5	12	26	25÷28	M8	A.R.	5 H9	32	22	20	58	560
C990-150 D14	149	53	-	44	38	24,5	28,5	12	26	25÷28	M8	A.R.	14	32	22	20	58	592
C990-175 D05	174	58	-	48	40	24,5	33,5	16	26	26÷36	M8	A.R.	5 H9	32	28	26	80	775
C990-175 D16	174	58	-	48	40	24,5	33,5	16	26	26÷36	M8	A.R.	16	32	28	26	80	765
C990-200 D05	198	63	-	53	44	24,5	38,5	17	26	28÷42	M8	A.R.	5 H9	36	28	27	90	1075
C990-200 D20	198	63	-	53	44	24,5	38,5	17	26	28÷42	M8	A.R.	20	36	28	27	90	1060
C990-250 D05	250	67	-	58	60	29	38	22	36	36÷50	M8	A.R.	5 H9	36	28	27	90	1560
C990-250 D20	250	67	-	58	60	29	38	22	36	36÷50	M8	A.R.	20	36	28	27	90	1545

dv= 36 mm.

















It's possible to increase the hole, by boring, until dm.













A.R.= Upon Request.

C – SOLID CONTROL
HANDWHEELS

ROLLMEX

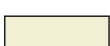
COLOUR CHART

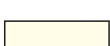
R A L			
COLOUR		RAL	CODE
Black		9011	01
Orange		2004	02
Orange		2011	03
White		9010	04
Blue		5002	05
Blue		5005	06
Blue		5015	07
Blue		5018	19
Blue		5019	21
Blue		5010	22
Yellow		1007	09
Yellow		1021	10
Grey		7024	12
Grey		7035	13
Red		3000	16
Green		6024	17

O T H E R C O L O U R S			
COLOUR		REF.	CODE
White		-	52
Blue		-	53
Blue		pant. 645 U	54
Blue		pant. 300	55
Grey		-	57
Grey		-	59
Grey		NCS 7500	60
Red		-	64
Red		-	65
Natural		-	66
Green		-	70
Brown		-	71
Cream		-	72
Violet		-	73



WWW.ROLLMEX.FI

ROLLMEX Oy

Takojankatu 4 - 33540 TAMPERE
Push. 010-6661122 - Fax 03-3640072
tamper@rollmex.fi

Karjalankatu 21 - 15140 LAHTI
Push. 010-6661121 - Fax 03-7511026
lahti@rollmex.fi

AUTHORISED RESELLER